

Pos.	Designation
1	Fuel bin
2	Feed auger
3	Stainless steel burner tube
4	Gas combustion tube
5	Convection tubes
6	Sprinkler
7	Exhaust outlet
8	Refractory material
9	Ash bin
10	Combustion blower
11	Microprocessor control
12	Sight glass

Construction

The REFO boiler is made of 6mm certified boiler steel and tubing. The circular shape of the boiler is a clear advantage, since this construction eliminates residual welding stress. The working temperature is always in excess of 61°C, owing to the use of a by-pass thermostat and a pump in the return line. This arrangement prevents corrosion. For the combustion chamber and the gas combustion tube only replaceable stainless steel and ceramic elements have been used. This ensures perfect combustion without radiant heat losses when the gas is being burned. In every respect these are boilers with a long working life.

Control panel

The REFO microprocessor control panel has a very user friendly design. The user interface consists of a control thermostat, an overheat thermostat, a knob for fuel type / fuel quantity, a main switch and a button for forced auger operation. There is also a digital display showing the smoke temperature.

The control system automatically adjusts to the varying heat requirements throughout the year, so that the output of the REFO boiler varies between 10% and 100%. However the lower limit depends on the condensation level in the smoke stack.

All the electric wiring is carried out in the factory; for the connection to the mains an earthed 230 V plug is to be used.

Safety

The auger feed from the bin to the boiler has a pitch which helps to prevent the fire from moving backwards. During operation the blower produces an overpressure in the bin for the same reason. The auger tube is further provided with a thermostat controlled sprinkler, with a water container mounted inside the boiler cabinet.

Maintenance

The REFO boiler has vertical boiler tubes with the draught going downwards in the tubes. This is a great advantage since dust and ashes from the combustion fall downwards in the smoke chamber (no need to clean the boiler very often). For cleaning, the boiler door is opened and the ash bin with fly ash and dust can be pulled out and emptied.

General Technical Data for REFO boilers

Models :	REFO 30, 40, 50, 80, 120
Fuel bin:	0.33, 0.7, 0.8, 4.0 and 10.0 m ³ and larger self build.
Water capacity of boiler:	150 litre
Test pressure:	6 bar
Working pressure:	2.5 bar
Bypass thermostat for boiler protection:	71°C
Combustion blower:	80 watt
Circulation pump:	Fitted
Gear motor:	330/700 L=0, 22kW, 780 L=0,37kW
Dimensions: (REFO 30,40,50)	H=1420mm, B=725mm, L=1480mm (330)L=1980mm(700),L=2460mm(780)
Flue dimension:	Ø 155mm & Ø 200mm
Flow and return:	1", 1¼" & 1½"
Mains connection:	230 Volt 3 phase (1 phase extra)



The REFO boiler has been on the Danish market since 1992. Today it is a thoroughly tried quality product with many well thought-out details and completely in tune with present day requirements.

FARM 2000 / TEISEN PRODUCTS LTD
 Bradley Green, Redditch, Worcs. B96 6RP.
 Tel: 01527 821621. Fax: 01527 821665.

REFO The clean burning fully automatic boiler from Denmark with so many advantages:

- Burns woodchip, wood pellets, grain, rape mash, shredded timber and sawdust/shavings etc.
- Smokeless. Oxygen trim.
- Can burn wide range of woodchip size, from 0% water up to 40% water content. *
- Can be used in sealed / pressurised systems.
- Tested to European Standard EN303-5
- Very high efficiency 85-94%.
- Minimal chimney requirement.
- Variable output. Can modulate 10% - 100%.
- Easy operation.

Teisen Products Ltd
www.farm2000.co.uk

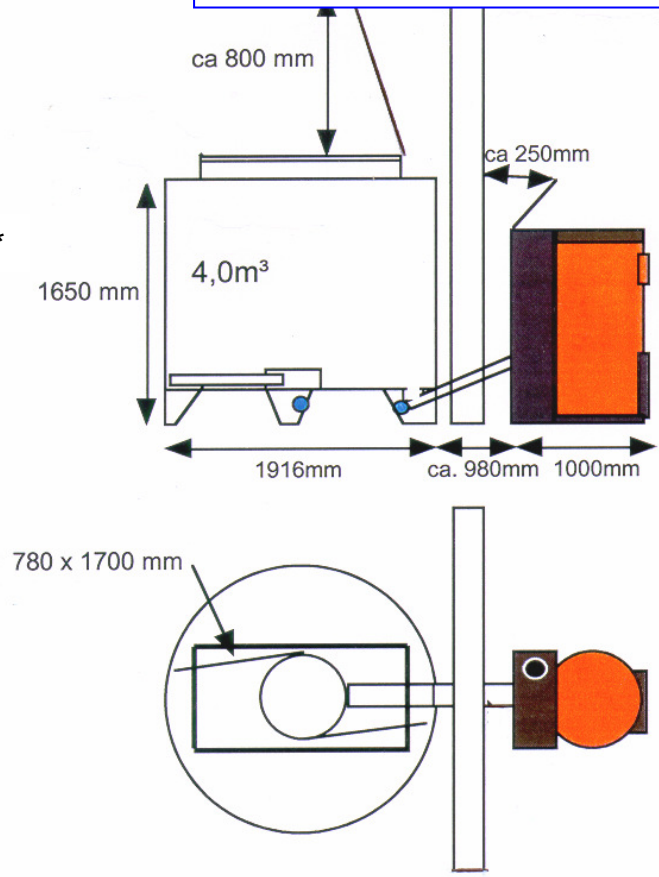

Model	Max. Output kW *					All figures are approximate
	Wood Pellets 7% water	Grain 13% water	Woodchip 20% water	Woodchip 26% water	Woodchip 35- 40% water	
REFO 30	28	26	25 (8.25kg/hr)	23	15	
REFO 40	37	36	34	31(10kg/hr)	20	
REFO 50	47	45	43	38	25	
REFO 80	85	73	75	70	40	
REFO120	120	105	100	90	60	

1. 1 litre gas-oil produces approx 7.5 kWhrs (in 75% efficient boiler).
 2. 1litre gas oil is replaced by 2.4 kg woodchip (26% water)
 2.0 kg wood pellets
 2.3 kg grain (13%-17% water)
 3. 1kg woodchip (26% water) produces 3.1 kWhrs.
 4. Average woodchip 220 kg / cu.metre. Average wood pellets 670 kg / cu.metre.
 Average grain 780 kg / cu.metre. (Wheat produces more slag than barley)

* max. output potential reduces with increased water, bark, soil/sand/grit content. The maximum outputs are only achievable with clean, dry, woodchip free of contamination, and with low bark content.
 If in doubt send a sample of your proposed fuel.

REFO 30, 40 and 50 require approx 2 metres of 155mm i.d. insulated chimney (HT).
 REFO 80 and 120 require approx 3 - 4 metres of 200mm i.d. insulated chimney (HT).

Teisen Products reserve the right to make amendments to spec. without notice.

FARM 2000 / TEISEN PRODUCTS LTD
 Bradley Green, Redditch, Worcs. B96 6RP.
 Tel: 01527 821621. Fax: 01527 821665.