

FARM 2000 HTR & BBR Ranges

M&K PRODUCTS (BROMSGROVE) LTD, DODFORD, WORCS, B61 9BT, UK ☎(01527) 836444 ✉heat@farm2000.co.uk

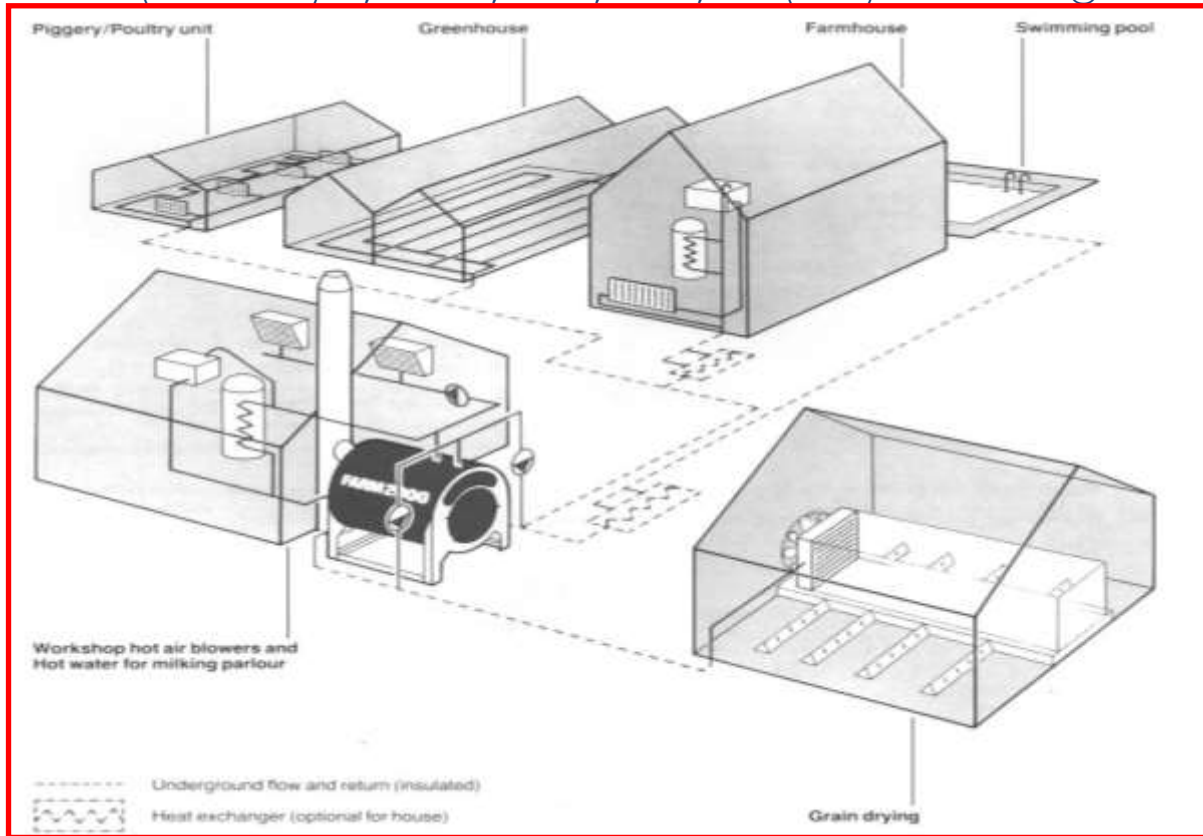

INSTALLATION AND OPERATING INSTRUCTIONS FOR BOILERS FIRED ON WOOD AND/OR STRAW

A.	IMPORTANT INFORMATION	2.
B.	INTRODUCTION	3.
C.	FUEL - GENERAL USE	3.
D.	GENERAL NOTES ON SITING AND INSTALLATION	3.
E.	CHIMNEY	5.
F.	PLUMBING	7.
G.	ACCUMULATORS	8.
H.	FAN CONTROL UNIT (TS2 & TS2E)	13.
I.	ASSEMBLING AND SETTING OF BOILER COMPONENTS	23.
J.	COMMISSIONING AND ROUTINE OPERATION	30.
K.	24 hr. THERMOSTATIC CONTROL WITH 5°C NIGHT SET-BACK	33.
L.	SAFETY	33.
M.	MAINTENANCE	34.
N.	CONTROL BOX WIRING DIAGRAMS	35.
O.	TROUBLE SHOOTING GUIDE	39.

TS2 & TS2E - CONTROL

See www.farm2000.co.uk for typical installations and video of boiler operation.

M&K PRODUCTS (BROMSGROVE) LTD, DODFORD, WORCS, B61 9BT. Tel: 01527.836444

A. IMPORTANT INFORMATION – BEFORE you begin

Retention of this Instruction Book

This Instruction Book must be kept handy for reference as it contains important details on the safe and proper use of the boiler. Read carefully and understand the following instructions before proceeding with the installation and operation of the boiler.

WARNING! DANGEROUS VOLTAGE



- Only a competent, suitably qualified electrician should install a FARM2000 Fan Control Unit
- Fan Control Unit must be wired via a double pole switched fuse or plug and socket. This supply must not be connected through a time switch or other control device.
- Cabinet should be fixed in position before MAINS connection [230VAC/ 50Hz/16 or 32 amp]
- Care should be taken when adjusting internal fuses as MAINS is present in the cabinet
- Fan Control Unit should not be exposed to water

Visual check on the condition of the Control Box and exposed electrical cables should be undertaken on a daily basis before lighting the boiler. Should the Control Box be distorted by heat or any wiring potentially exposed to fire/melted, the Control Box should be isolated from MAINS supply and a qualified electrician sought.

WARNING! BOILER SHOULD ONLY BE OPERATED BY A COMPETENT PERSON FAMILIAR WITH THIS INSTRUCTION BOOK



WARNING

- Boiler room must be well ventilated, kept swept clean and free from fuel and combustible material. A hose and fire extinguisher must be available at all times between the boiler and exit from the boiler room.
- NEVER leave the boiler unattended when the combustion chamber main door or small stoker door is open whilst it is alight.
- Do not allow children into the boiler room
- Boiler should only be fired when accumulator and heat demand can absorb entire fuel charge, i.e. fan operates without interruption. Fuel should only be re-loaded when there is no fire or embers in boiler. However, if the fuel does re-ignite from embers at the back, always ensure that the fire is not smothered by fuel and that flame is well established at the front before starting fan. Failure to do so can lead to a build-up of smoke / un-ignited gases causing pressurisation and blowback.
- Always take care when opening either the main or stoker door. Stand back and to one side; do not peer into the combustion chamber.
- Ensure that the fan is operating when opening the small stoker door. Do not open within one hour of stoking the boiler
- Do not open small stoker door if there has been a failure in the power supply.
- Always switch the fan off when opening the main boiler door.
- In the event of a power failure, where overheating occurs, turn on the heating system and / or turn on the hot taps to cool the system. If necessary extinguish the fire using sand, soil or damp gravel - do not use water.
- If water is lost from the system and the boiler while it is still hot DO NOT TOP IT UP - this could result in an explosion. Wait until the boiler has cooled down and call in a heating engineer.
- Ensure that the chimney, flue box, heat exchanger tubes and area above the combustion plate are always kept clean. Failure to do this can cause a build-up of pressure and possible blow-back when the door or stoker door is opened. In certain circumstances it could even lead to an explosion.
- Make sure the door is fastened open during stoking, so it cannot swing closed inadvertently.
- When cleaning ash out of the boiler a suitable dust mask should be worn. Dampen down with water if necessary.
- Appropriate gloves should be worn when handling hot ash or boiler parts
- The boiler must be fully drained if left in an exposed frosty condition unlit.



CAUTION

- Make sure that hot ash is disposed of safely.
- A safety advice label is fitted on the boiler. If it has been removed or is illegible or damaged, then contact Teisen Products for a replacement.

B. INTRODUCTION

Your **FARM 2000 BOILER** is a sound investment which will provide low cost heat for many years. To ensure the best operation of your boiler and long service, **we strongly recommend that you follow these instructions closely. Incorrect installation and operation of the boiler will reduce its service life.**

If you have any boiler problems that cannot be answered from this instruction book, please contact **Teisen Products** direct. **Teisen Products** supply suitable chimneys.

These instructions apply to the **FARM 2000 HTR and BBR boiler range**, which can be fired on both wood and/or straw

Wearing/Service Parts: Please be aware that steel air distribution parts used in the combustion chamber may need replacing every 2 – 5 years depending on fuel being used and boiler operation. Insufficient air, premature idling or use of some waste woods may shorten their life.

C. FUEL – GENERAL USE

FARM 2000 HTR and BBR boilers are certified for RHI on logs and/or cereal straw only (check specific boiler details for acceptable fuels). They are not suitable for burning fossil fuels such as coal, coke, oil or gas. At the same time, use of industrial waste wood or contaminated wood is not acceptable for RHI use, and can also cause boiler corrosion.

Efficient operation can only be achieved with dry fuel. Emissions and outputs are based upon moisture contents up to 20% for wood and 17% for cereal straw. Levels above this will reduce outputs and efficiency, may cause incomplete combustion (producing smoke), and increase ash and deposits in the boiler and chimney. Excess moisture can also cause corrosion.

WOOD - should be felled before spring, stored for at least 2 years, and be under a roof for at least 6 months before the winter of use, somewhere where the wind can get at it, but not the rain.

CEREAL STRAW - When using cereal straw, good results are only obtained if the straw is left for at least 5 days before baling. In addition, straw burns best, and with less ash, if it has been rained on i.e. grey straw rather than yellow straw (rain washes the potash out of the straw, returning it to the soil). However, the straw must then be baled when it is dry without dew, and stored under cover. Lightweight-to-medium density bales (approx. 100-110kg/cu metre) burn best. High density bales do not burn well. The extra work involved in producing weathered but dry straw helps ensure efficient boiler operation in winter.

If possible use straw from light sandy soil. Straw from heavier/clay soils tends to produce more ash which means more frequent cleaning out of the boiler, and reduced output.

DO NOT BURN TYRES, PLASTICS, RUBBER ETC, OR ANY FORM OF FOSSIL FUEL. THIS IS NOT ONLY DANGEROUS BUT WILL DAMAGE THE APPLIANCE AND INVALIDATE ANY WARRANTY CLAIM.

D. GENERAL NOTES ON SITING AND INSTALLATION

FOR DETAILS ON CHIMNEY AND PLUMBING, SEE SECTION C and D.

The following criteria apply when choosing a site for the boiler:

1. Ease and convenience of fuel handling. Fuel must be stored under a roof **adjacent** to the boiler room, **not in it**.
2. The boiler should be installed external to the dwelling area.
3. Site the boiler where a suitable chimney can be erected, or an existing chimney utilised (*See Section C*)
4. The boiler should be positioned so the cold feed and open vent are protected from frost, and where there is some form of gravity heat leak (*See Section D&E*).
5. The boiler can be installed remote from the heated requirement, with insulated underground pipework *provided an accumulator is installed next to the boiler, or that there is some form of heat leak.*

Boiler should be installed according to this booklet and the following;

- The boiler must be installed in a fire-proof boiler room, which should NOT be an integral part of a domestic dwelling.
- The boiler must only be installed by a competent heating engineer.

- The boiler, chimney and system should be installed in compliance with current relevant Building Regulations and B.S. Codes of Practice for solid fuel appliances, flues and chimneys
- All electrical work should be carried out to current I.E.E. Standards.
- The installation should conform to Local Authority and Water Board Regulations.
- There must be no valves in the cold feed or open vent.
- The boiler should be under cover, fully protected from the weather, with adequate ventilation for the boiler at the rate of 1 sq. ft. per 250,000 BTU/hr. (0.12m² per 100 kW).

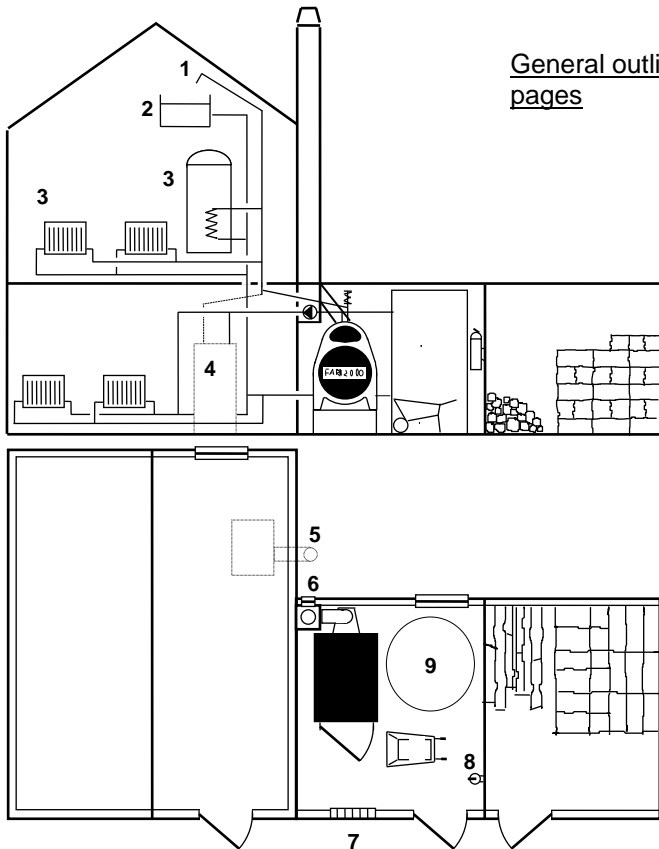

General outline installation for reference only . For full details see later pages

1. Open Vent.
2. Cold feed and expansion.
3. Gravity circuit.
4. Existing oil/gas fired boiler (optional) (pumped circuit)
5. Separate chimney for existing boiler.
6. Access for chimney cleaning.
7. Ventilation at floor and ceiling level.
8. Fire extinguisher.
9. Accumulator tank

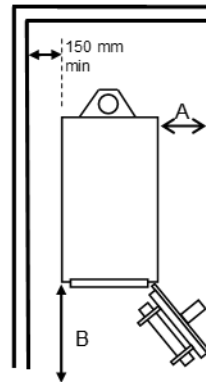

Recommended minimum boiler clearances from walls etc to allow correct opening of boiler door and allow full access when stoking.

	A	B
HT36/46	550mm	850 mm
HT50	625mm	1020mm
HT60/70/80	770mm	1380mm
BB144/BB146	1230mm	1770mm
BB244		
BB154/BB254	1380mm	2050mm

Min 150mm clearance on non-hinged side of boiler on all models.

- The boiler **must** be on a level concrete or brick surface. For Big Bale Boilers ensure the door **cannot** swing closed by gravity, and arrange for the door to be secured whilst stoking. Big Bale Boilers should be installed in their final position and the door checked before plumbing. If it is felt the door can swing closed, the rear of the boiler can be shimmed up to provide a more neutral action.
- HT boilers should be raised by approx. 300 - 400mm on a plinth to suit wheelbarrow. This makes stoking and de-ashing easier.
- There must be good access to the rear of the boiler for cleaning the flue box and chimney.
- Allow clearance in front of the boiler for tube cleaning (i.e. length of combustion chamber plus, at least 100 mm.)
- There should be no combustible material in the boiler room, which should be constructed from non-combustible materials.
- There should be a fire extinguisher and water hose accessible from the boiler and boiler room door.
- An ash rake and tube brush rod are included in all boilers. BB boilers also come with an ash scoop which can be customized to attach to a fork lift, tractor telehandler etc to assist in cleaning the boiler. All items need to be removed before initial firing of boiler.

NOISE LEVELS

The following airborne noise level data applies to FARM 2000 HTR boilers; at 1m. from free blowing fan (A-weighted sound pressure level, dB (A) reading) This is given in order to comply with the European 'Machinery Directive'.

HT70R	(G2E140 4µF fan)	67 dB(A)	HT80R	(G2E180 fan)	75 dB(A)
BB144/3R	(G3G-180 fan)	67 dB(A)	BB244/3R	(VBL9 fan)	95 dB(A)
BB146/3R	(G3G-180 fan)	67 dB(A)	BB254/3R	(VBL9 fan)	95 dB(A)
BB154/3R	(G3G-180 fan)	67 dB(A)	BB254H/3R	(VBL9 fan)	95 dB(A)

E. CHIMNEY

The boiler's efficiency and output are dependent on a well designed chimney. The two functions of a chimney are to disperse the exhaust gases, **and** to provide adequate draught through the boiler so the fuel always burns under a negative pressure. Failure to achieve this results in inefficient combustion, a dirty boiler and boiler corrosion. It can also cause dangerous blow-backs during operation.

The chimney should rise vertically from the boiler flue spigot, preferably with no bends or elbows, and its minimum height from the flue box spigot is shown below: Boiler life will be significantly reduced if these recommendations are not followed.

The chimney is made up from sectional lengths and is **not** self supporting. It must be secured to a wall (if sufficient height is available) or to a steel mast as shown. Chimney support mast to be sourced locally.

To test chimney draught (do this when boiler and chimney are warm), open the small stoker door when there is a fire in the boiler, and if smoke emits continuously, the draw is likely to be inadequate.

We strongly recommend a straight chimney without bends for best performance and prolonged boiler life.

BOILER MODEL	MIN. LENGTH H (M)
HT70R	7.5
HT80R	9.2
BB144/3R	8.3
BB146/3R	9.2
BB154/3R	9.2
BB244/3R	9.2
BB254/3R	11.7
BB254H/3R	11.7

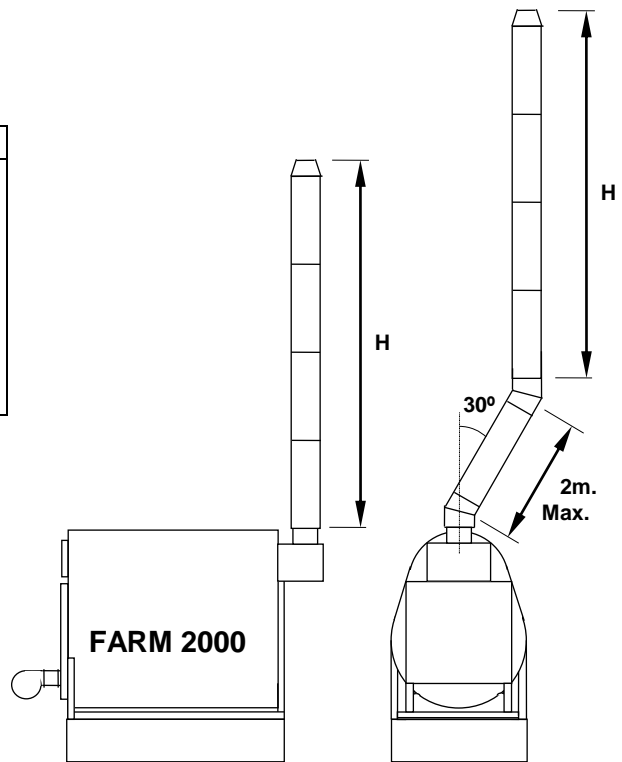

* all angles quoted to the vertical

The Chimney must be higher than surrounding buildings and be insulated to the top, to prevent cooling of the flue gases.

There must be no horizontal lengths of flue pipe and, if the boiler is being connected to an existing brick chimney, this should be via a 30° elbow*; only if space does not permit should a 45° elbow* be used. If a chimney has to be routed round an obstruction use 15° or 30° elbows*. There must never be more than **two** elbows in a chimney.

Ensure that all of the chimney can be swept.

The most suitable chimney is sectional, insulated (50mm thickness), twin wall stainless steel. This type of chimney provides a better draught than a brick chimney, and is easier and less costly to install.

STAINLESS STEEL INSULATED CHIMNEY
(can be supplied colour powder coated to suit)

This is not a working drawing and is for guidance only. Details of mast specification, foundation, supports and chimney should be checked by installer, taking local conditions and building regulations into account.

Chimneys must have 50mm of insulation						
Internal Diameter (mm)	175	200	250	300	350	
A	Maximum length of chimney boiler can support (m)	7	6	7	4	4
B	Maximum length of unsupported chimney (m)	1.7	1.7	1.7	1.7	1.7
C	Recommended max. distance between Brackets (m)	3	3	2	2	2
D	Maximum length of chimney above an intermediate vertical support (m)	8	8	7	6	5

Chimney Diameter **must not be less** than the the boiler flue spigot diameter.

CHIMNEY MAST SECTION GUIDE	
Chimney Height above ground (m)	R.H.S. Section *
8.1m	150 x 150 x 8
9.1m	180 x 180 x 8
10.6m	200 x 200 x 10
11.3m	250 x 250 x 8
12.6m	250 x 250 x 12.5

*This section can be reduced in sheltered areas or if part of chimney is inside building.

If the 50 mm insulated chimney passes through, or near, a wall or ceiling, the outer skin must be at least 100 mm from any combustible material. For extra protection fit a stainless steel heat shield sleeve in front of any woodwork. **Uninsulated** (single wall) flue pipe must have at least 500 mm clearance **and** a heat shield.

Further information on chimney, mast and mast foundation available on request. See drg. 410/1

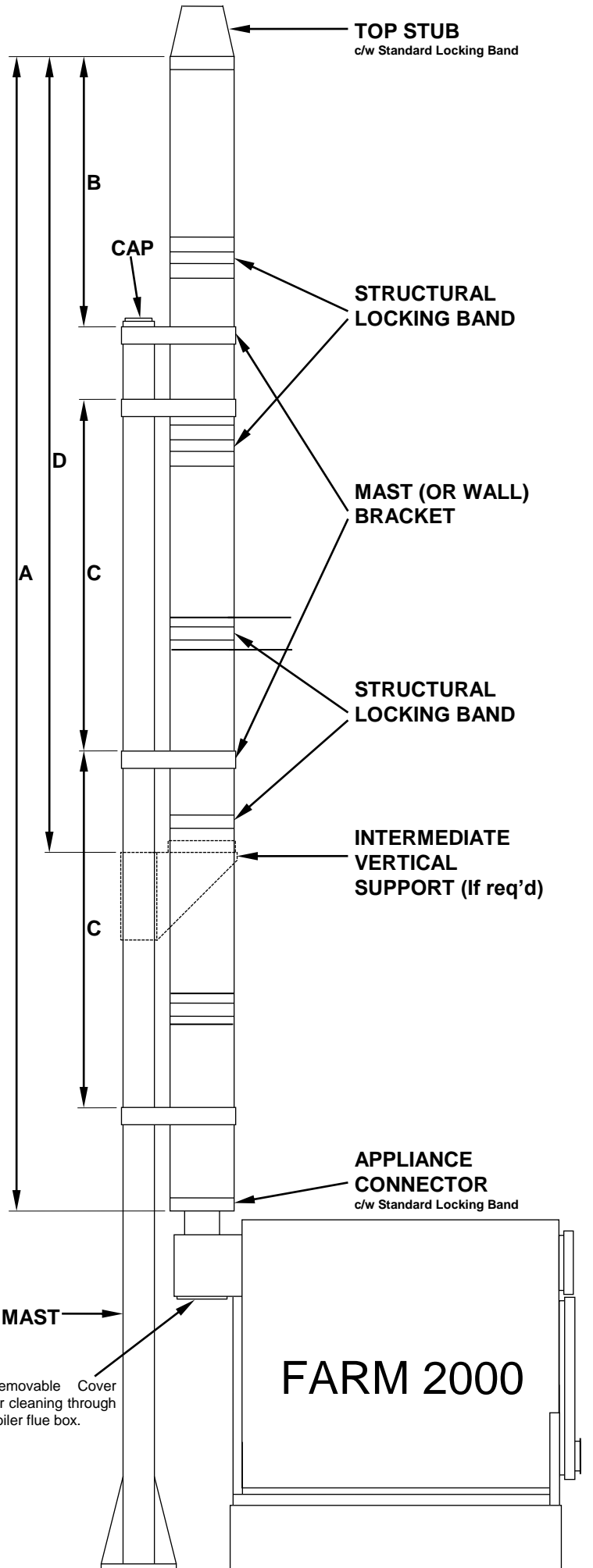

F. PLUMBING (Including Accumulators)

FARM 2000 HTR and BBR Boilers are Low Temperature Hot Water Boilers (LTHW), and should only be fitted to open vented, indirect heating systems, via an accumulator tank.

In addition to the guidelines given under Section B, the following requirements must be observed:-

- Boiler must always have its own separate cold feed and open vent pipes.
- Open vent, **which must have a continual rise**, must always discharge into the feed and expansion tank.
- There should be no valves in the cold feed or open vent. (If valves are fitted, the handles must be removed, labelled and the operator clearly instructed. Operating a boiler with a valve closed can be highly dangerous.)
- All pipework should be black iron (medium gauge) or copper. Fittings must be able to withstand boiling water

The table below shows minimum sizes of cold feed, open vent and overflow pipes.

BOILER MODEL	COLD FEED		OPEN VENT		OVERFLOW	
	Iron	Copper	Iron	Copper	Iron	Copper
HT70R	1"	28mm	1¼"	35mm	1"	28mm
HT80R & all BB Boilers	1½"	40mm	2"	50mm	2"	50mm

- The feed and expansion tank should be capable of withstanding boiling water and preferably be of galvanised iron with sufficient capacity to allow the water in the system to expand by 3.5% **without** overflowing. We therefore recommend the feed and expansion tank capacity should be 6% of total water in system.
- The float valve should be fitted with a copper float to withstand the effects of overheating.
- Overflow pipe from the feed and expansion tank **must** be copper or iron.
- A safety valve must be fitted to suit the static head of water (refer BS759). The minimum discharge aperture should be 1½", and should be directed away from any passer-by. (Teisen Products can supply)
- A pumped shunt system should be included to prevent back-end corrosion, improve combustion and overall efficiency. For systems without accumulators, a small domestic circulating pump can be used, controlled by a thermostat installed on the main return pipe. The thermostat should be wired to maintain the return temperature above 57°C.

For systems with an accumulator the shunt is controlled via the flow temperature using a clamp-on pipe thermostat wired to make on a rise in temperature (60°C).

- The thermostats and temperature gauge must be positioned in the boiler jacket, primary flow or shunt circuit if it is a fully pumped system. **Do not fit them in a "blind" pipe.**

G. ACCUMULATOR SYSTEMS

All HTR and BBR Boilers must be fitted with accumulator.

Accumulator system has the following advantages:-

- Enables low stoking frequency (typically once/twice per day)
- Enables boiler to operate at higher combustion efficiency, due to un-interrupted burn
- Allows increased flexibility of stoking times with improved convenience i.e. you can stoke when you want to, rather than when you have to.
- Stores heat ahead of requirement (e.g. grain drying, greenhouse, piggery night time heating etc)
- Acts as heat leak.
- Ensures clean combustion with lower maintenance and cleaning requirement.
- Prolongs boiler life

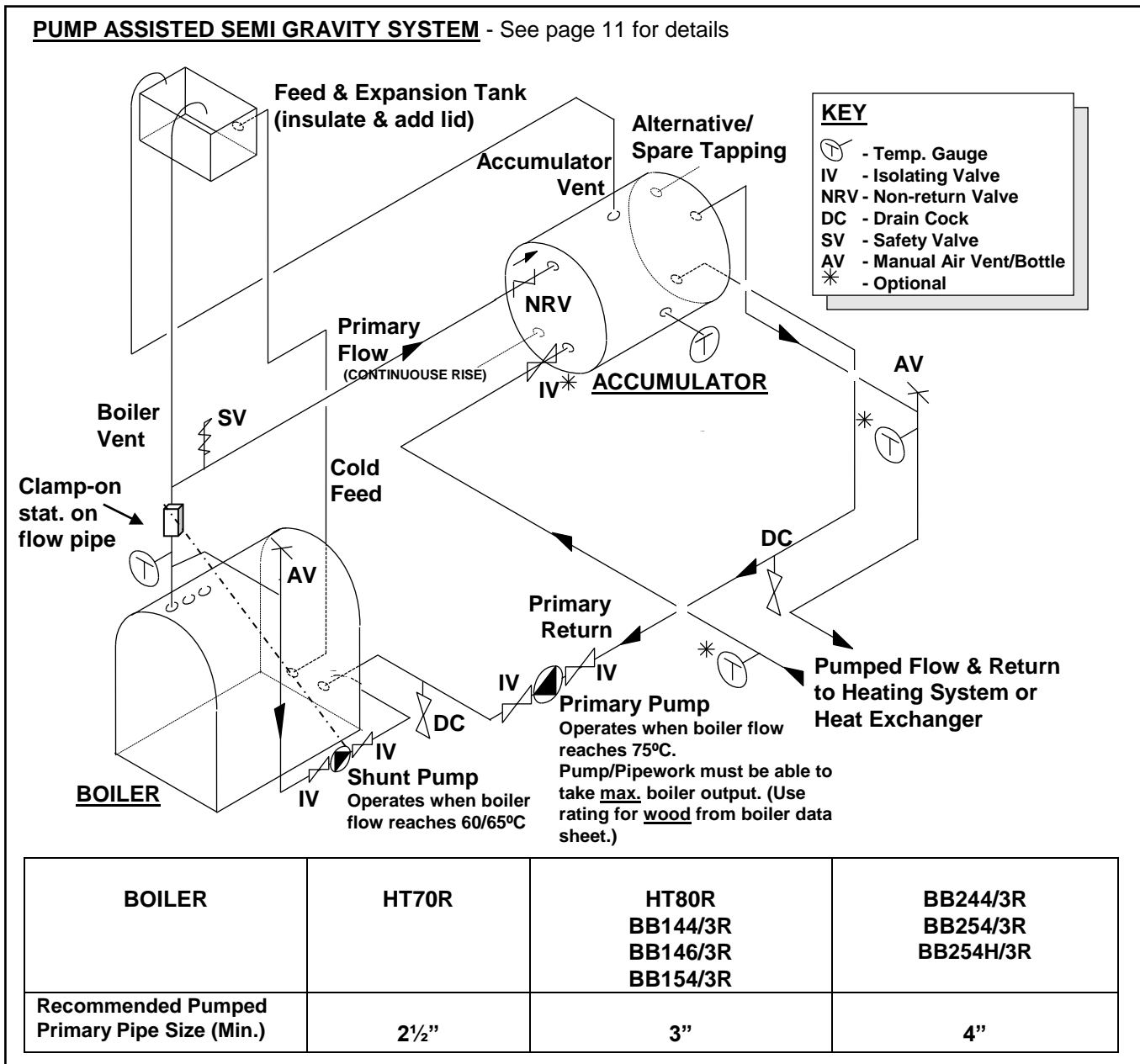

Important: See also Typical boiler and accumulator system/remote system (page 10 & 11)

GRAVITY ACCUMULATOR SYSTEM

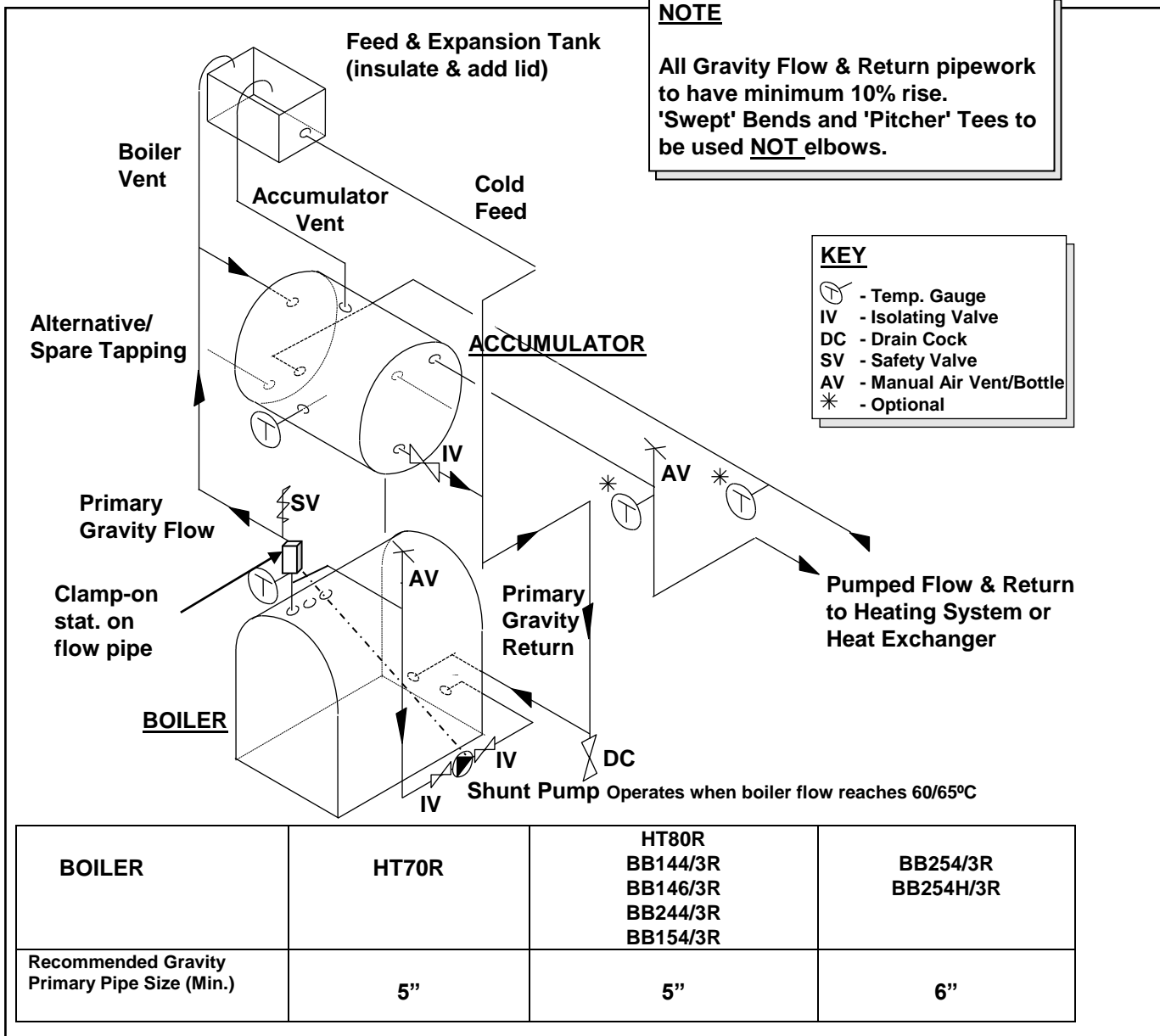

General Notes:

- Galvanised F. & E. tank capacity at least 6% of total water content. Cold fill to at least 50mm depth.
- Open vent at highest point. Boiler and accumulator **must have** continuously rising open vent.
- Heat demand outlet to be at **opposite end** of tank from primary flow from boiler, and from opposite end of demand return. Return to boiler to be at **opposite end** of tank from primary flow.
- Accumulator to have minimum 100mm glass wool insulation or equivalent spray foam on all surfaces.
- Recommended water capacity **as big as possible**, ideally at least 80litres/kW output. Sufficient to absorb at least half the energy value of the fuel in the boiler (1000 gallons/4500 litres stores 450,000 BTU's or 135 kWhs)
e.g. HT80R. Minimum water capacity 15600 litres, BB154/3R 19000 litres.
The above are min. capacities. For maximum efficiency and convenience, we recommend at least 50% larger.
- Accumulator must be raised fully above boiler if gravity circulation only is required (i.e. no pump).*
- Boiler control should be set to approximately 85°C. Primary pump should be set as high as possible without the boiler overheating (i.e. 75 °C or above)
* For pump assisted gravity system, i.e. accumulator on ground next to boiler, top of accumulator should preferably be at least 60cm above top of boiler, the higher the better.

Important: See also Typical boiler and accumulator system/remote system (page 11 & 12)

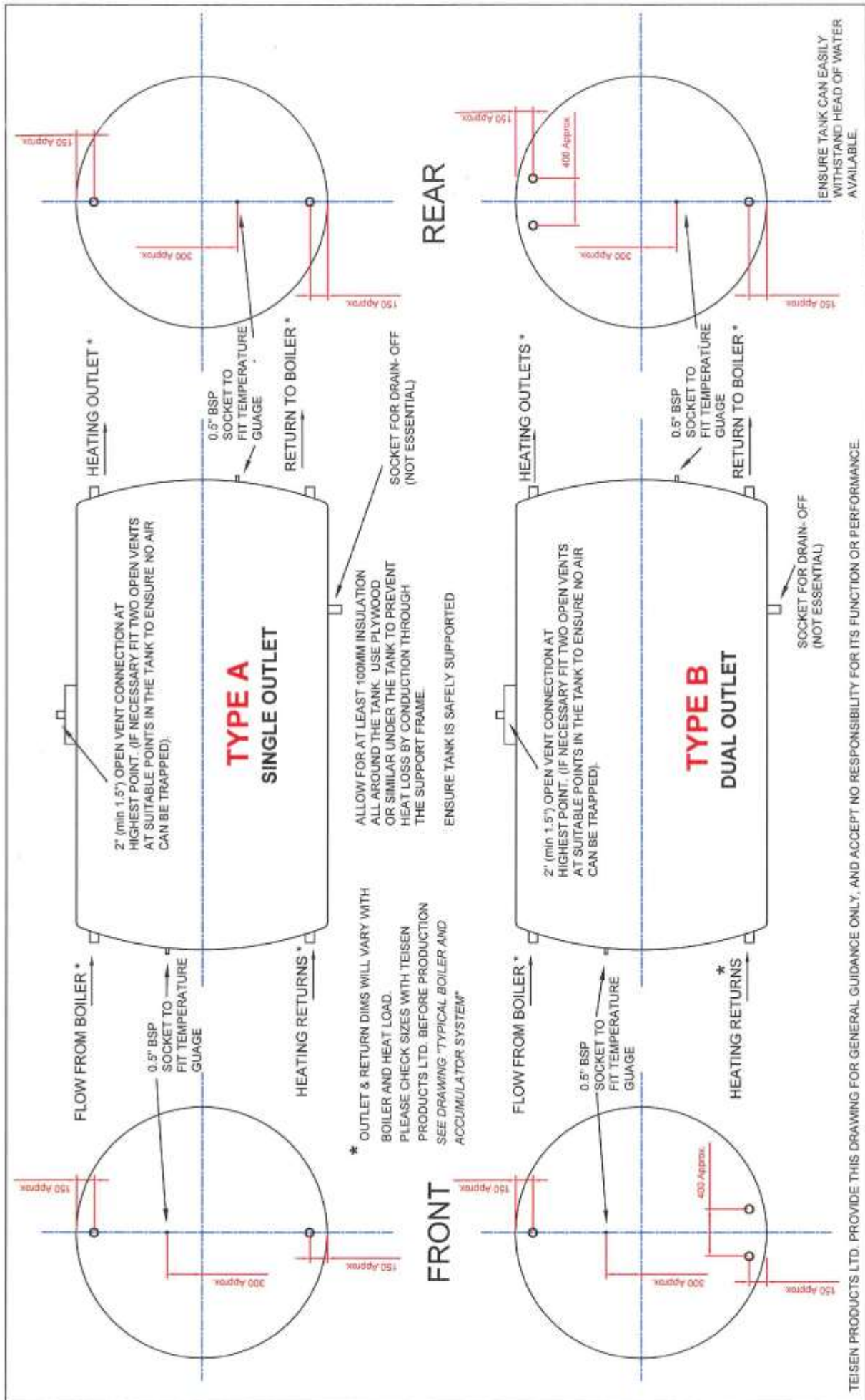

TEISEN PRODUCTS LTD. PROVIDE THIS DRAWING FOR GENERAL GUIDANCE ONLY, AND ACCEPT NO RESPONSIBILITY FOR ITS FUNCTION OR PERFORMANCE.

FARM2000 M&K PRODUCTS (BEOHEBCKOBE) LTD Dorford, Evesham, Warwick, B91 9BT Tel: 01527 521631 Fax: 01527 521655		USED ON	
TITLE TYPICAL HORIZONTAL ACCUMULATOR TANK		DRG. No.	A & B
DRAWN	DATE	MATL.	SCALE
TLW	01/13		1:30
No.	DATE	ALTERATION	
The original of this drawing is the exclusive property of M&K Products Ltd. and the acceptance of this print constitutes an agreement that it will be treated as a confidential document to be used for no other purpose other than aid in the assembly or operation of the equipment or as otherwise expressly authorised by M&K Products Ltd. These drawings are not to be communicated, disclosed, copied or published except as expressly authorised in writing by M&K Products Ltd.			

ENSURE TANK CAN EASILY WITHSTAND HEAD OF WATER AVAILABLE.
 ALLOW FOR AT LEAST 100MM INSULATION ALL AROUND THE TANK. USE PLYWOOD OR SIMILAR UNDER THE TANK TO PREVENT HEAT LOSS BY CONDUCTION THROUGH THE SUPPORT FRAME.
 ENSURE TANK IS SAFELY SUPPORTED.

2" (min 1.5") OPEN VENT CONNECTION AT HIGHEST POINT. (IF NECESSARY FIT TWO OPEN VENTS AT SUITABLE POINTS IN TANK TO ENSURE NO AIR CAN BE TRAPPED).

* OUTLET & RETURN DIMS WILL VARY WITH BOILER AND HEAT LOAD. PLEASE CHECK SIZES WITH TEISEN PRODUCTS LTD. BEFORE PRODUCTION. SEE DRAWING "TYPICAL BOILER AND ACCUMULATOR SYSTEM" * ADDITIONAL SOCKETS ETC MAY BE ADDED IF REQUIRED.

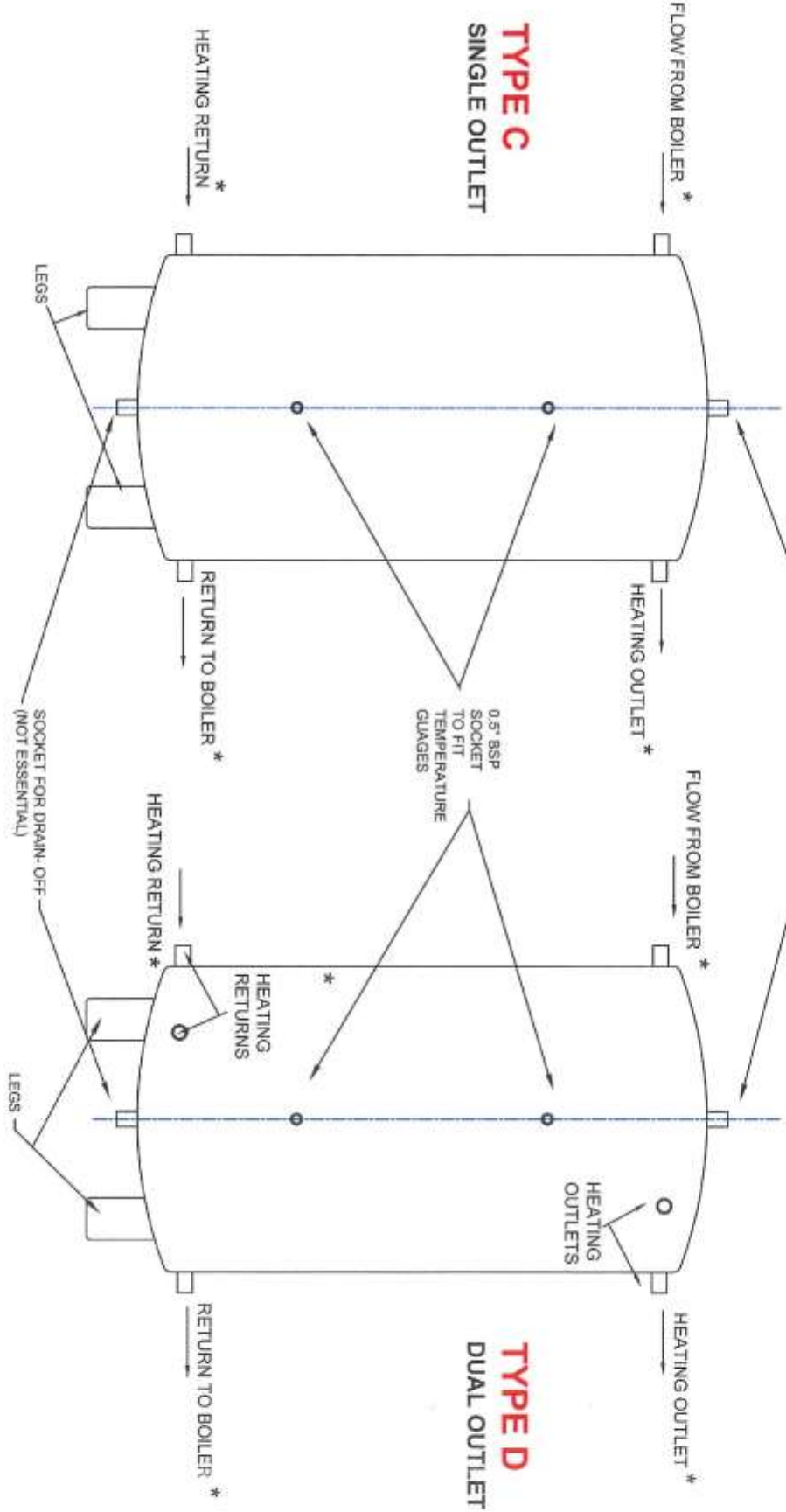

TEISEN PRODUCTS LTD. PROVIDE THIS DRAWING FOR GENERAL GUIDANCE ONLY. AND ACCEPT NO RESPONSIBILITY FOR ITS FUNCTION OR PERFORMANCE.

<p>FARM2000 M&K PRODUCTS (BROMSGROVE) LTD Dated, Birmingham, West, 9th 1987 Tel: 01527 821621 Fax: 01527 821663</p>		<p>The original of this drawing is the exclusive property of M&K Products Ltd. and the acceptance of this print constitutes an agreement that it will be treated as a confidential document to be used for no other purpose other than aid in the assembly or operation of the equipment or as otherwise expressly authorised by M&K Products Ltd. These drawings are not to be communicated, disclosed, copied or published except as expressly authorised in writing by M&K Products Ltd.</p>	
No.	DATE	ALTERATION	
<p>TITLE TYPICAL VERTICAL ACCUMULATOR TANKS</p>		<p>DRAWN</p>	<p>DATE</p>
<p>TLW</p>		<p>01/13</p>	<p>MATL</p>
<p>SCALE</p>		<p>1:30</p>	<p>DRG. No.</p>
<p>C & D</p>			

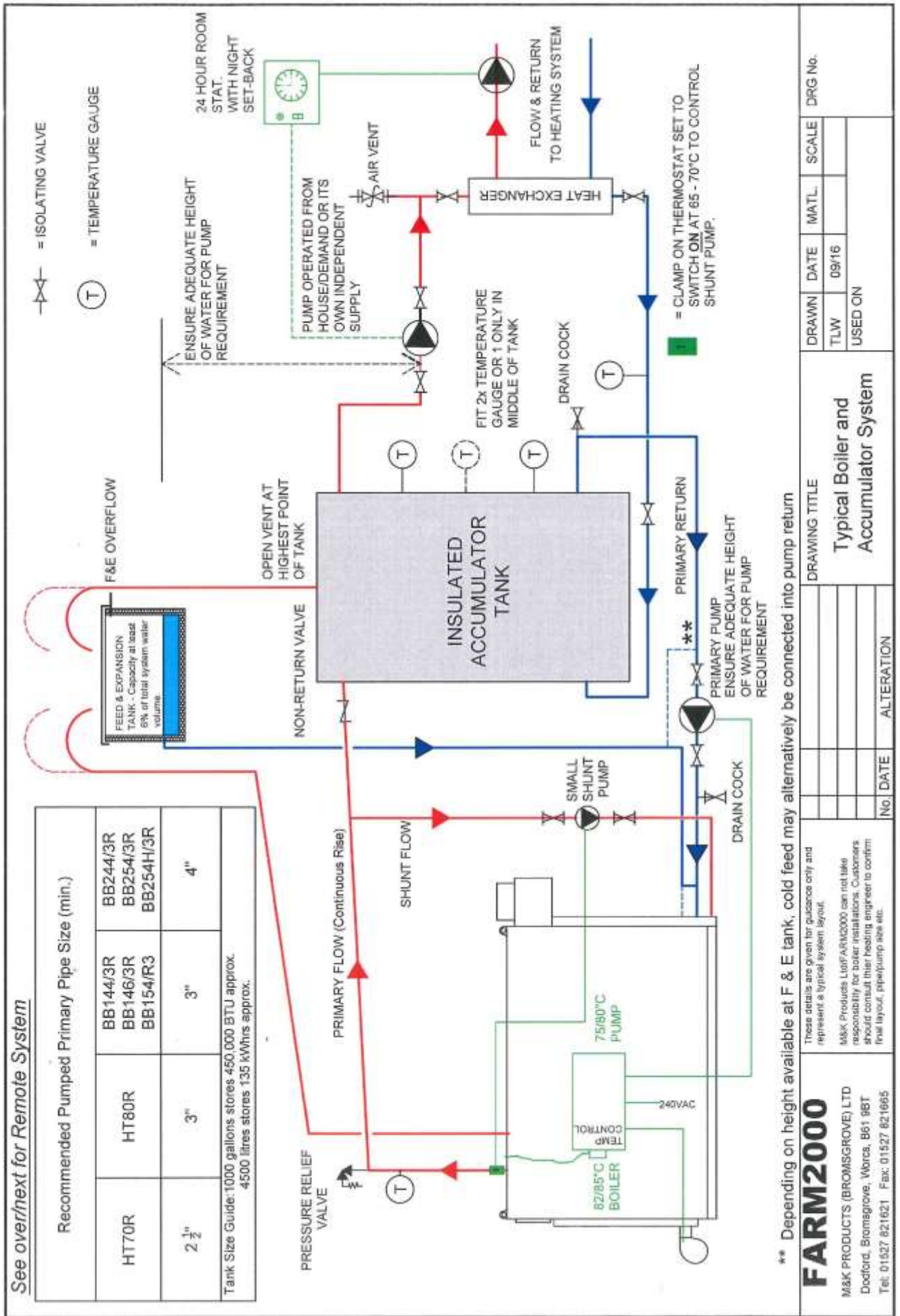

** Depending on height available at F & E tank, cold feed may alternatively be connected into pump return

FARM2000

M&K PRODUCTS (BROMSGROVE) LTD
 Dodford, Bromsgrove, Worcs, B61 9BT
 Tel: 01527 821621 Fax: 01527 821665

These details are given for guidance only and represent a typical system layout.
 M&K Products Ltd/FARM2000 can not take responsibility for boiler installers. Customers should contact their heating engineer to confirm final layout, pipe/pump size etc.

DRAWING TITLE

Typical Boiler and Accumulator System

DRAWN	DATE	MATL	SCALE	DRG No.
TLW	09/16			
USED ON				

No.	DATE	ALTERATION

See over/next for more detail

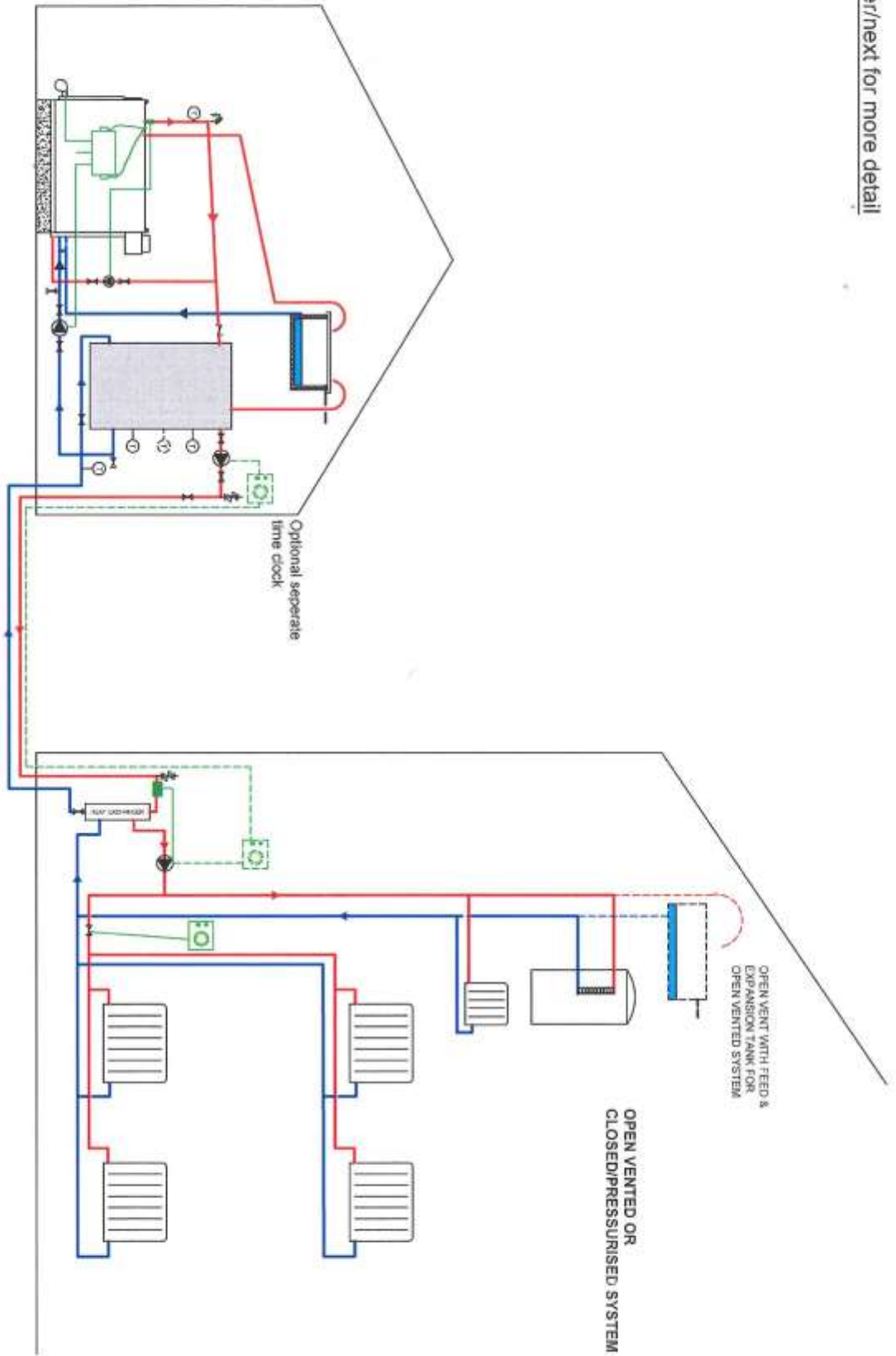

FARM2000

M&K PRODUCTS (BROMSGROVE) LTD
 Doodford, Bromsgrove, Worcs, B61 9BT
 Tel: 01527 821621 Fax: 01527 821665

These details are given for guidance only and represent a typical system layout.
 M&K Products Ltd/FARM2000 can not take responsibility for boiler installations. Customers should consult their heating engineer to confirm final layout, pipework size etc.

No.	DATE	ALTERATION

DRAWING TITLE
**Typical Boiler and
 REMOTE Accumulator
 System**

DRAWN	DATE	MATL	SCALE	DRG NO.
TLW	01/13			
USED ON				

H. FAN CONTROL UNITS

1. FARM2000 TS2 CONTROL – used on boiler models HT70R, HT80R, BB144/3R, BB146/3R, BB154/3R from October 2016

Control overview

The TS2 control monitors the boiler’s water temperature and running time to control the **combustion fan, primary circulation pump and shunt pump** at different times throughout the combustion cycle.

When burning straw the TS2 control also operates the motorised primary/secondary air damper.

The system comprises a colour display with 4 button user input plus connector interface for temperature sensors, pumps and combustion fan, etc.

It is strongly recommended that all electrical components (e.g. pumps, thermostats, control box etc.) are wired from the same source of supply.

TS2 Layout of user interface

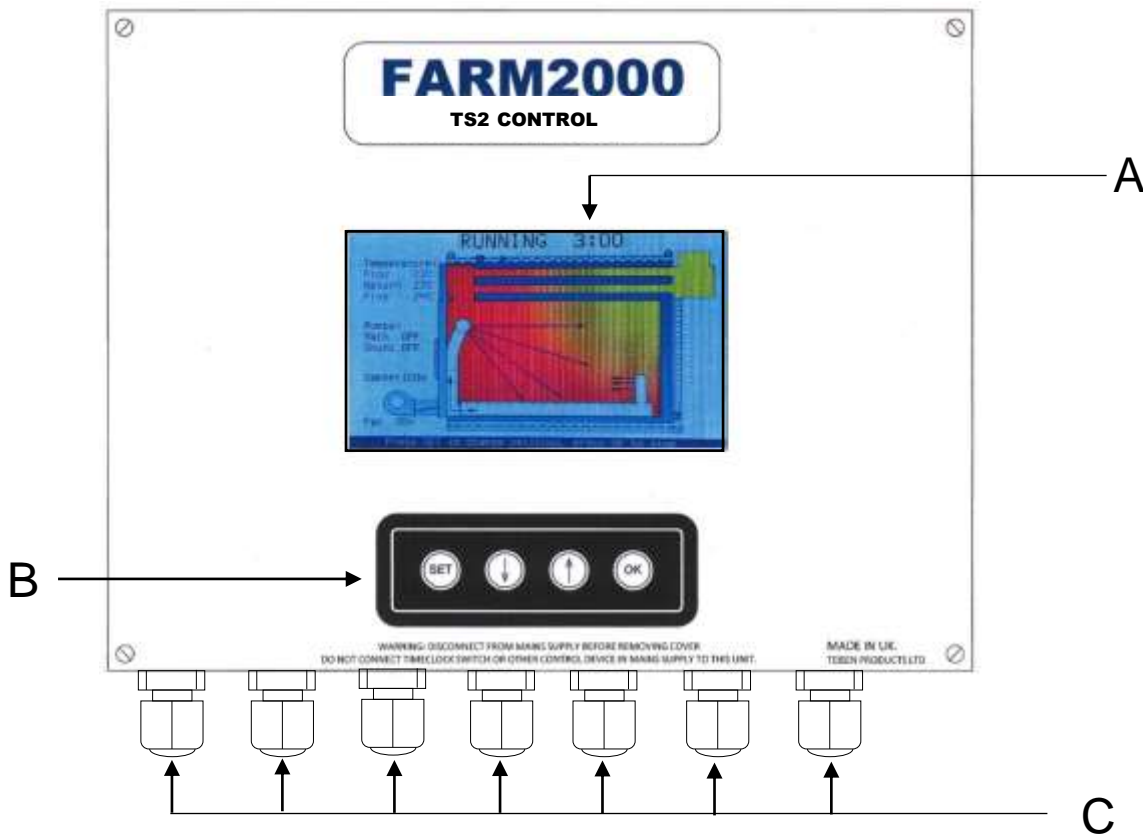

Part	Function
A Display	<ul style="list-style-type: none"> displays boiler status displays SETUP menu displays parameters and their ranges displays comment/instruction with each parameter
B User input	<ul style="list-style-type: none"> SET - selects SETUP menu - selects SETUP parameter to be modified ↑ & ↓ - navigates SETUP menu - increases/decreases parameter value

		<ul style="list-style-type: none">• OK - start/stop operation - accepts SETUP parameter changes - exits SETUP menu
C	Cable glands	<ul style="list-style-type: none">• cable entry to control box for sensors, pumps and fan, etc

TS2 Electrical Supply

Supply Voltage: 230V/50Hz AC single phase supply

Supply current: 6 amps max.

Board Fuses: 6 amp, 20mm F type fuse - outputs

1.25 amp, 20mm F type fuse - control board power supply.

2. FARM2000 TS2E CONTROL – used on boiler models BB244/3R, BB254/3R and BB254H/3R from October 2016

Control overview

The TS2E control utilises an AC drive mounted in the control cabinet to convert a 32 amp, 230V/50Hz single phase input to a 230V/50Hz three phase output to drive the boiler fan.

The TS2E control monitors the boiler's water temperature and running time to control the **combustion fan, primary circulation pump and shunt pump** at different times throughout the combustion cycle.

When burning straw the TS2E control also operates the motorised primary/secondary air damper.

The system comprises a colour display with 4 button user input plus connector interface for temperature sensors, pumps and combustion fan etc.

It is strongly recommended that all electrical components (e.g. pumps, thermostats, control box, etc.) are wired from the same source of supply.

The control display, variables and their setting are identical in both TS2 and TS2E variants of the boiler control. This manual then refers to both the TS2 & TS2E variant unless any specific differences exist.

TS2E Layout of user interface

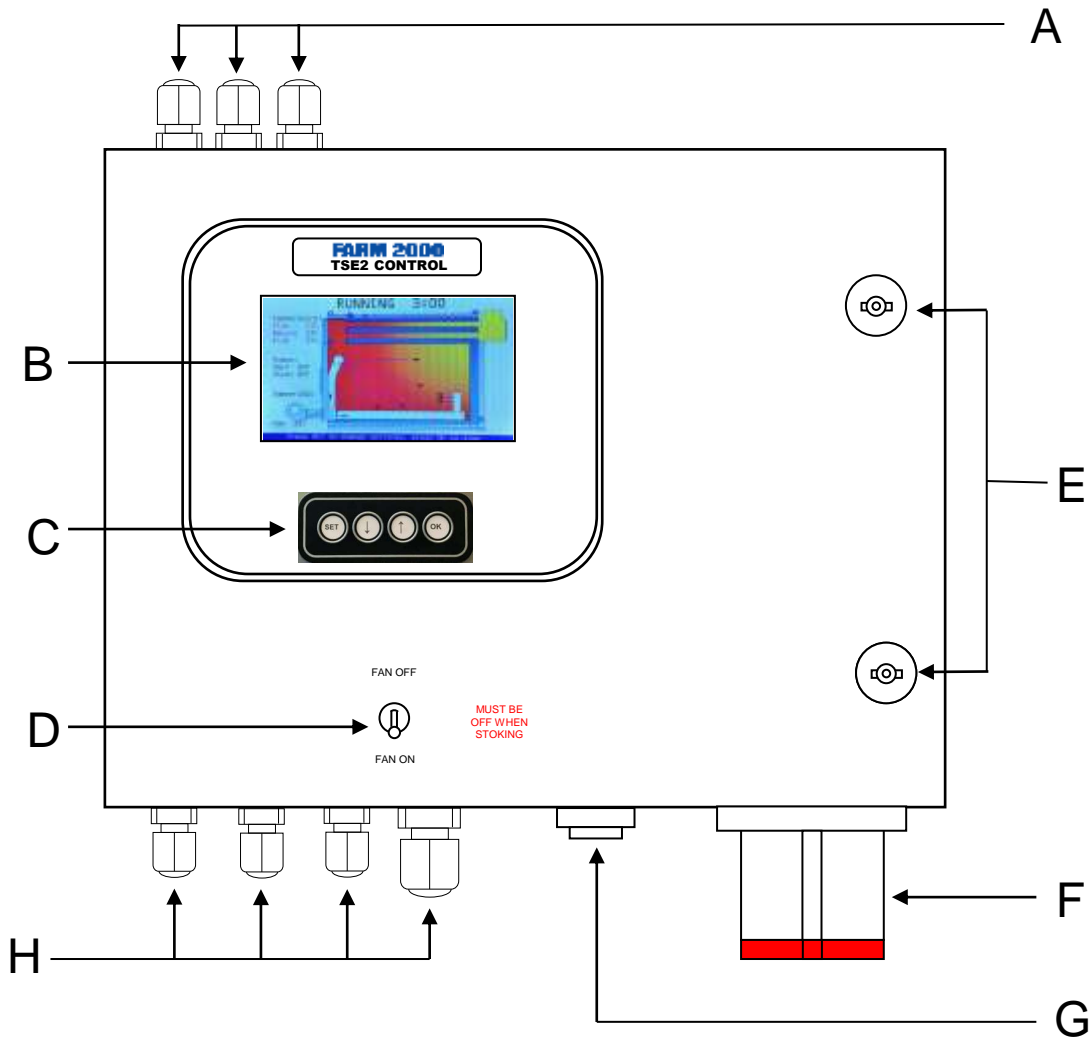

Part	Function
A	<ul style="list-style-type: none"> • Flow Water Temperature Sensor • Return Water Temperature Sensor • Flue Gas Temperature Sensor (Optional)
B	<ul style="list-style-type: none"> • displays boiler status • displays SETUP menu • displays parameters and their ranges • displays comment/instruction with each parameter
C	<ul style="list-style-type: none"> • SET - selects SETUP menu - selects SETUP parameter to be modified • ↑ & ↓ - navigates SETUP menu - increases/decreases parameter value • OK - start/stop operation - accepts SETUP parameter changes - exits SETUP menu
D	<ul style="list-style-type: none"> • Manual fan on/off switch
E	<ul style="list-style-type: none"> • For access to control cabinet fuses etc.

F	Motor Connector	<ul style="list-style-type: none"> 32 amp 230V/50Hz 3 phase motor connector
G	Damper Connector	<ul style="list-style-type: none"> 3 pin 230V/50Hz single phase connector
H	Cable glands	<ul style="list-style-type: none"> cable entry to control box for 32 amp mains supply, primary pump, shunt pump and optional chimney fan control

TS2E Electrical Supply

Supply Voltage: 230VAC/50Hz single phase supply
 Supply current: 32 amps max.
 Board Fuses: 6 amp, 20mm F type fuse - outputs
 1.25 amp, 20mm F type fuse - control board power supply.
 Control Fuses: 20 amp MCB - supply input
 6 amp MCB – primary pump

Control screen options.

Display layout – Boiler operating

Boiler Status

Timer Status hr:min

Temperature Displays

Pump Status

Damper Position
100% = all secondary air
0% = all primary air

Fan Speed

Comment/Instruction line.

Display layout - Setup

Parameter list

Help guide

“Selected” Parameter

Set values

Display layout – Modify selected parameter.

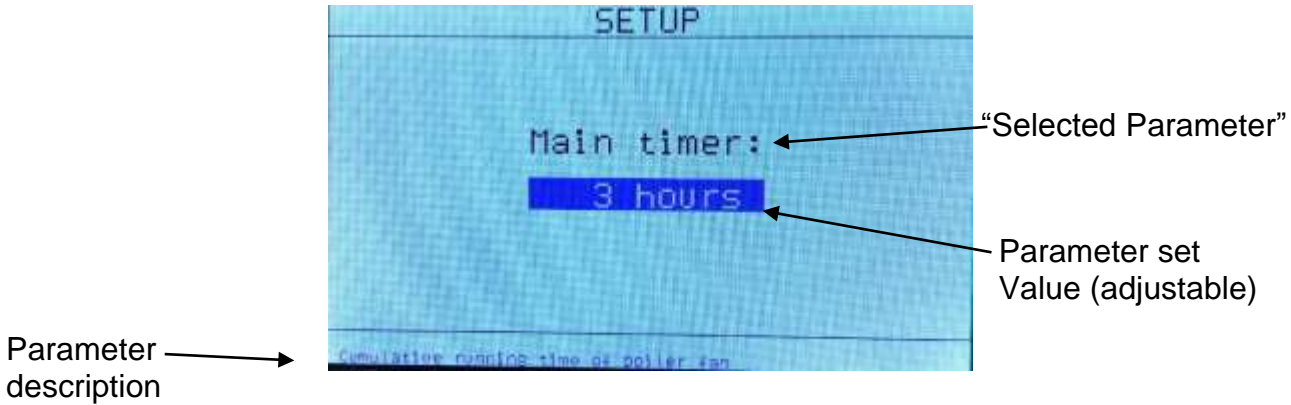

User input

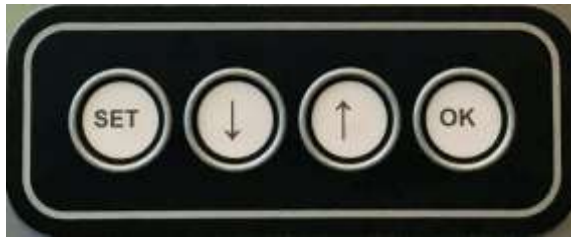

The control is addressed via a simple 4 button user input which is used to stop/start the boiler operation and select/set required operating parameters and values.

All boilers are also fitted with a manual fan on/off switch used to turn the boiler fan on/off when the stoker door is opened etc. Dependant on boiler model this is located in the control unit or on the boiler fan itself.

Mounting TS2 & TS2E Control Units

The TS2 control is generally mounted on the side of the boiler on the same side as the boiler door hinges, using the 4x No8 self-drilling screws supplied,

the TS2E control cabinet is mounted with 4x No8 self-drilling screws plus cabinet mounting brackets supplied with the boiler.

The TS2 control unit mounting plate is designed to provide approx. 25mm clearance behind the control housing to allow easy routing and access for sensor and power etc. cabling.

The control unit should be located a minimum of 300mm back from the boiler front plate, on the "flat" section of the boiler casing/cladding.

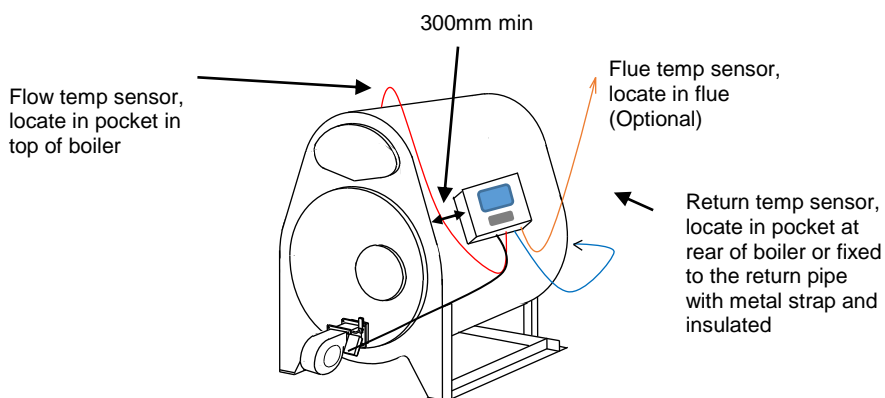

Fit the FLOW temperature sensor in the brass pocket located in the top of the boiler, making sure the sensor is pushed to the bottom of the pocket and held in place by spring clip supplied.

Fit the RETURN temperature sensor in the brass pocket in the back of the boiler, making sure the sensor is pushed to the bottom of the pocket and held in place by spring clip supplied; or fix to the return water pipe immediately behind the boiler using metal cable ties etc, before fully insulating.

The optional Flue temperature sensor can be fitted in the boiler chimney. To fit this sensor drill a 6mm diameter hole through both inner and outer walls of the chimney approx. 500mm to 1000mm above the flue spigot.

Insert the flue sensor into the chimney until the end of the steel sensor body is flush with the outer surface of the chimney.

Alternatively, the control unit may be mounted on a suitable wall or stand but care must be taken that the fan loom and/or sensor cables are of sufficient length to reach the intended mounting position.

The control and fan must be fully protected from water ingress, exposure to direct rain, etc. which will damage the control system.

The control must be installed by a qualified electrician in accordance with all current electrical rules and legislation.

All cables must pass through the cable grommets provided in the control enclosure.

Connect TS2 control to a 230VAC/50Hz/16amp mains supply and the TS2E to a 230VAC/50Hz/32 amp mains supply via a double pole switched fuse.

This supply ***must not*** be connected through a time clock switch or other control device.

When accessing control box/cabinet care should be taken not to disturb 2x ribbon cables connecting display, etc. to control board.

OPERATION

Start Sequence – at power up.

If the control is being connected to the mains supply for the first time or the mains supply has been interrupted at any time, the start sequence will differ slightly from normal operation as follows,

- Turn mains supply on at main isolator
- Display will show “WAIT” for approx. 15 secs while system reads sensors.
- Display will change to show READY
- Press SET to enter the SETUP screen or press OK to start the combustion cycle, display will then show RUNNING.
- The display will show the set timer period as a countdown function.

Note: when the mains supply is first connected to TS2E system the fan will start to rotate immediately at slow speed, if the boiler is left in the READY mode the fan will fully stop after a short time.

Similarly when the boiler shows FINISHED, or OK is pressed to interrupt a cycle, the fan may take several minutes before coming to a complete stop.







Control parameter SETUP

The user may access the control SETUP menu at any time while the control is powered, and in general use. Parameters would generally, if required, be adjusted before a combustion cycle is started.

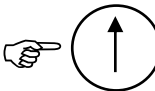
The user can however modify the SETUP parameters while the boiler is operating, i.e. fan speed, pump operating temperature etc. The boiler will continue to operate as normal as any changes are made.

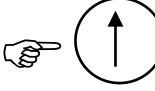
When the boiler is running any, changes to fan speed, etc. take immediate effect, i.e. fan speed will increase with each increment made on screen.

Note, if the “Manual operation of outputs” function is selected, all boiler operating functions will be inhibited.

- To enter the SETUP menu 
- To navigate parameter list  or 
- To select highlighted parameter 
- To set parameter value  or 
- To accept change and return to Parameter list  (use arrow keys to select next value or)
- To exit SETUP menu 

The following parameters are available to the user.

- Main Timer (1-12 hours)

This limits the total **accumulated running** time of the fan, and should be set to suit the type and quantity of fuel loaded. The operating range is 1 to 12 hours and as an approximate guide it should be set as **low** as possible to prevent cooling of the boiler whilst ensuring all of the fuel is completely burnt out. Depending on the fuel being used, the boiler will continue to produce output for some time after the fan has stopped.

- Primary pump operating temperature (15 - 100°C)

This sets the operating temperature for the primary circulation pump,

- a) when used to operate circulating pump from accumulator, set at approx. 75°C
- b) when boiler used without accumulator, can be set at 60°C to operate central heating pump, or set at 90°C to operate as a heat dump if separate pump control fitted in house (i.e. programmer or thermostat etc.)

If set too low, the pump will continue circulating after the boiler has cooled down, thereby cooling the accumulator
Note: if pumps requiring high electrical power or a three phase supply are fitted this output should be used to drive the pump indirectly via suitable control relay. Consult your electrician or FARM2000 for further information.

- Fan/Boiler control temperature (15 - 100°C)

Controls the fan to maintain the temperature of the water in the boiler - this must normally be set at approximately 82°C (not less than 80°C), and approximately 85°C with an accumulator system.

- Chimney fan start temperature (0 - 995 °C)

Provides on/off signal with respect to flue temperature if a chimney fan is fitted. Please contact Farm2000 for further details.

- Minimum flue temperature (50 - 350°C)

No function assigned to this parameter, default setting is 50°C

- Maximum flue temperature (50 - 400°C)

No function assigned to this parameter, default setting is 350°C

- Display of flue temperature value (Y/N)

Turns on/off flue temperature display, default setting is NO

- Fan Soft Start Period (0 -15 mins)

Sets time for which Speed 1 (soft start) operates. Should be set long enough to allow fire to fully establish without being “blown out” by the fan. See installation and operating manual for recommended settings.

If no soft start function required, set period to 0

- Fan speed 1 - soft start (0 - 100%)

Sets speed of fan during soft start period. See installation and operating manual for recommended settings.

- Fan speed 2 - main speed (0 - 100%)

Sets main fan speed. See installation and operating manual for recommended settings.

- Damper active (Y/N)

Turns damper control output on/off. Should be set to ON when burning straw.

When burning wood, damper should be turned OFF and manually set to ‘wood only’ on the damper scale

- Damper start delay (0 - 180mins) Sets delay period from the start of the combustion cycle before damper starts to operate. See installation and operating manual for recommended settings.

- Damper ON time (0 – 15 secs)

Sets damper motor ON time. See installation and operating manual for recommended settings.

- Damper OFF time (0 – 15 mins)

Sets damper motor OFF time. See installation and operating manual for recommended settings.

- Accumulator tank fitted (Y/N)

Controls operation of shunt pump.

With accumulator fitted (Y) shunt pump turns on when flow temperature reaches 60°C and turns off when flow temperature is 60°C or above, AND return temperature reaches 75°C

With NO accumulator fitted (N) the shunt pump turns off when return temperature reaches 60°C.

- Use 0-10V Signal to drive fan (Y/N)

Selects control input for boiler fans that are designed to be speed controlled using a 0-10V input.

This parameter will be factory set before boiler despatch, please consult FARM2000 before changing.

- Manual operation of outputs

This function can be used to test the function of all outputs, note that when this parameter is selected, all boiler functions will be inhibited, the fan etc will stop until selected for test, as soon as the user returns to the SETUP menu the boiler will return to normal operation.

*To avoid potentially hazardous operation **DO NOT** use the “manual operation of outputs” function during boiler firing.*

Fan ON/OFF switch.

All boilers are fitted with a FAN ON/OFF switch that allows the operator to manually turn the fan off, this switch is either mounted on the fan or alternatively on the TS2 control box/cabinet dependant on boiler model.

When the fan is manually stopped via the FAN ON/OFF switch the Control will display “**WARNING: FAN OFF**”

Switch should be **ON** whenever boiler is operating and **must** be switched **OFF** when **main door** is opened.

However, fan must remain **ON** if the **small stoker door** is re-opened after light-up (to avoid blow-back).

Start sequence – typical, i.e. next combustion cycle.

- Following completion of the main timer period (shown as a countdown sequence on the display) the display will show FINISHED.
- Pumps will remain operational until set control temperature is achieved.
- 15 seconds after the cycle has finished, the display will show READY.

When the display shows READY  to start cycle.

Damper operation sequence

- When OK is pressed to start cycle, damper will start to move to its home (start) position, the display will show DAMPER 100% when the home position has been achieved. (100% = all secondary air, 0% = all primary air)
- Regardless of actual damper start position the controller will operate the damper output for 2.5 mins to ensure damper is moved to the correct starting position.
- Damper will then operate as per set damper sequence.
- Damper may be manually adjusted by depressing the clutch button on the damper housing while rotating the “T” handle on the end of the damper shaft.

Shunt pump operation theory

The shunt pump operates under the following parameters:

Accumulator fitted -	Shunt pump turns ON when flow temp reaches 60°C
	Shunt pump turns OFF when Flow temp is 60°C and return temperature reaches 75 °C
No accumulator fitted –	Shunt pump turns ON when flow/return temperature is below 60°C
	Shunt pump turns OFF when return temperature reaches 60°C

Manual Testing of outputs.

Selection of “manual testing of outputs” function will inhibit all boiler functions, boiler will return to normal operation when the user returns to the setup menu.

IMPORTANT - to avoid potentially hazardous operation DO NOT use the “manual operation of outputs” function during initial boiler firing, this will turn off the fan and pumps while selected.*

The fan, pump and damper motor outputs can be tested by selecting “Manual Control of Outputs” in SETUP menu.

- From home screen press SET to enter table of variables
- Press ↑/↓ until Manual Control of Outputs is highlighted
- Press SET to enter variable
- All boiler functions will now be inhibited, i.e. fan and pumps will stop.
- Press ↑/↓ to highlight desired output
- Press SET to toggle selected output ON/OFF
- Press OK to display table of variables, boiler will resume normal operation.
- Press OK to return to home screen.

I. ASSEMBLING THE BOILER COMPONENTS

OVERVIEW:

Depending on intended primary fuel, STRAW vs. WOOD, the behaviour in Primary and Secondary air circulation within the boiler is different with regards to the damper, air diverter plate and rear air spreader. The configuration can be changed at a later date.

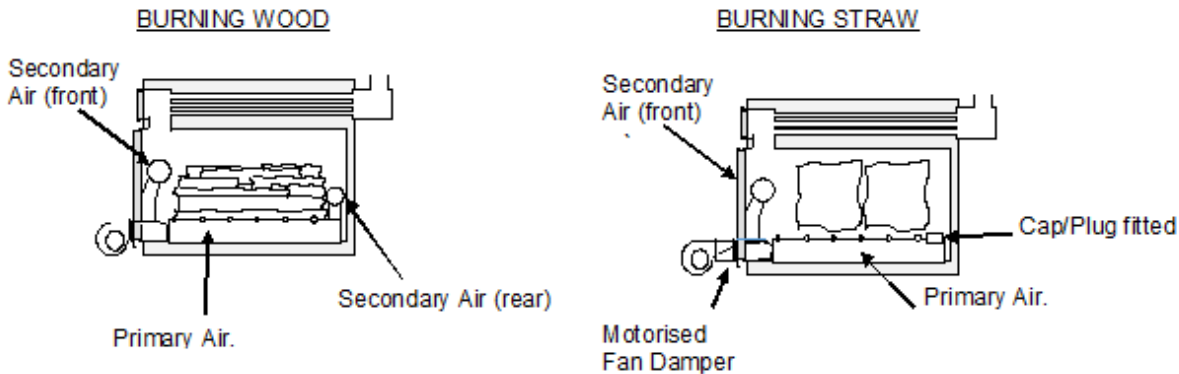

NOTE:

Straw only - Fit damper, no rear air spreader and cap/plug over rear air spreader fitting

Wood only - Omit damper. Rear air spreader must be fitted

Mixed fuel - Damper can be fitted (turned OFF for wood and ON for straw) and rear air spreader fitted as per instructions. If you wish to burn straw at a later date the damper can always be fitted

AIR DIVERTER PLATE for WOOD and STRAW

Boilers are supplied with the Air Diverter Plate set at the factory. Before assembling other control components to the boiler the position of the air diverter plate should be checked as necessary.

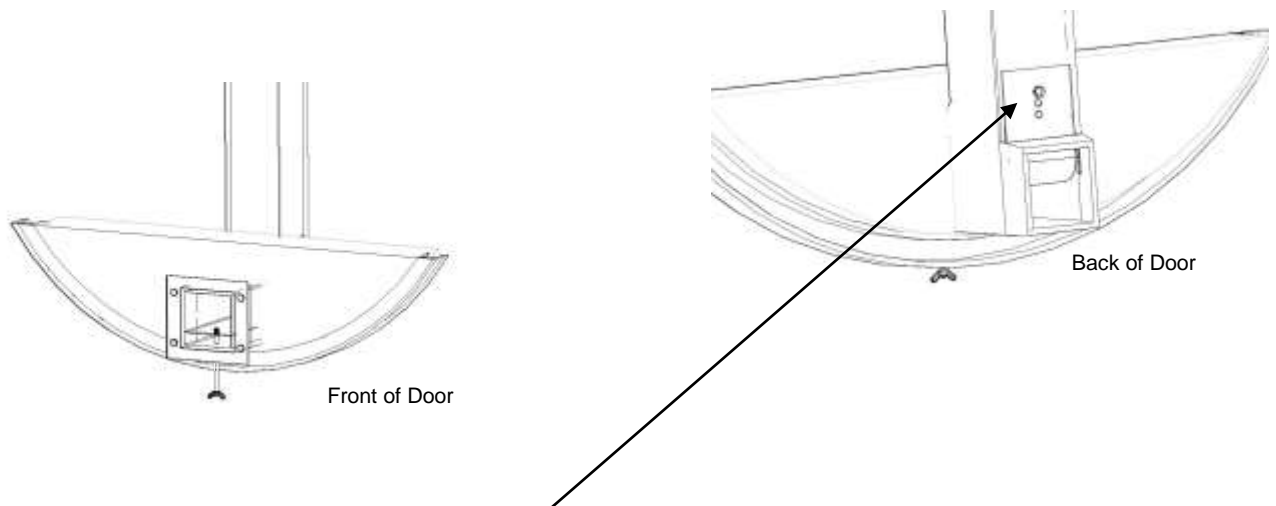

In HTR Boilers:

1. Air Diverter Plate fixing screw should be located in the middle hole of the diverter plate
2. The Air Diverter Plate is set as indicated to provide a gap between plate and BOTTOM of the box section
3. Turning the adjuster screw clockwise increases the primary and rear secondary air.

Air Diverter Plate settings:

<p><u>With motorised damper fitted</u></p> <p><u>Burning wood or straw</u></p> <p>50mm for HT70R & HT80R 70mm for ALL BB boilers</p>	<p><u>Without motorised damper fitted</u></p> <p><u>Burning wood only</u></p> <p>20mm for HT70R & HT80R 40mm for ALL BB boilers</p>
--	---

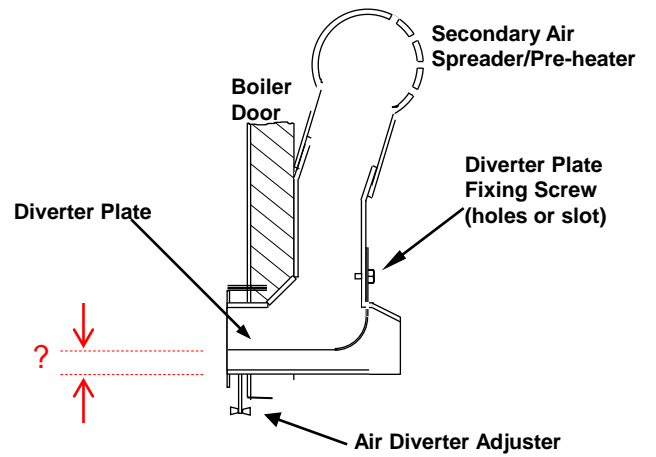

When WOOD BURNING only:

FITTING FAN:

Using the M6 x 16mm screws, nuts and washers provided, attach fan onto the flange on the door. *Note: a fan mount adaptor is fitted to boiler model HT80R to ensure a smooth air transition between fan and air distribution system.*

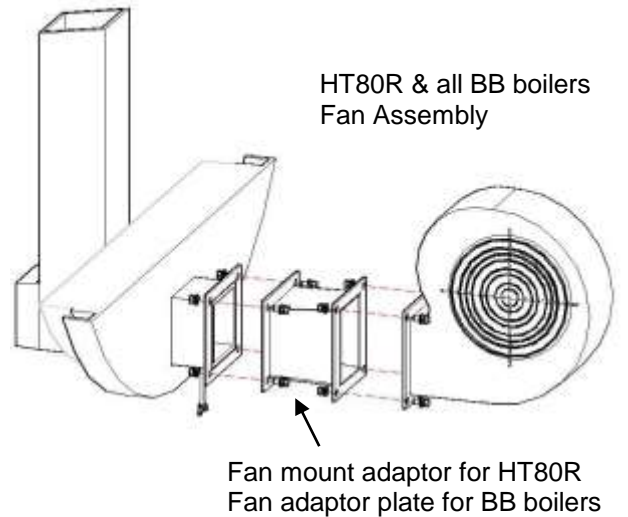
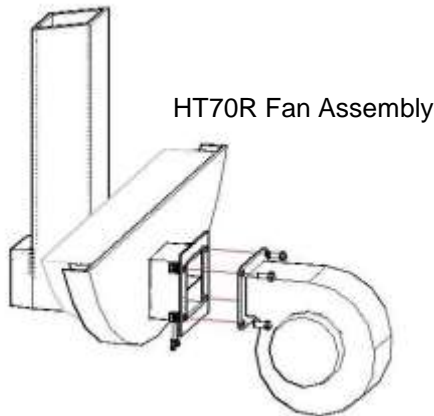

REAR AIR SPREADER AND BASE DUCT

When burning wood, boiler **must** be fitted with the rear air spreader mounted on rear of base duct.

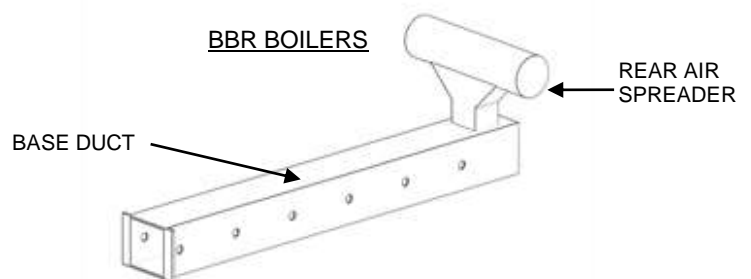
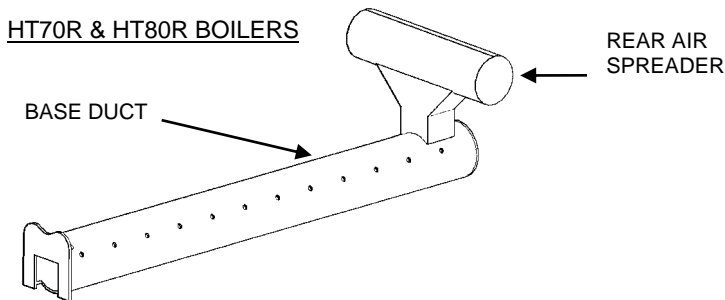

Base duct is square and reversible. Recommend it is reversed every 3-4 weeks to reduce likelihood of bending. Ensure rear air spreader is firmly located into base duct

When STRAW BURNING only:

Always ensure primary air nozzle on door 'mates' well into base duct opening – failure to do so will result in lack of air into duct and rear air spreader causing deterioration of ducting

MOTORISED AIR DIVERTER ASSEMBLY – HT70R & HT80R

1. Fix motorised damper assembly onto boiler door flange using 4x M6 nuts and washers onto M6 fixed studs

The damper has a horizontal fixed plate at one end of the damper assembly, this end is mounted next to the boiler door.

2. Fix fan to damper assembly using 4x M6 nuts and washers onto M6 fixed studs.
3. Plug damper assembly into 3 pin socket mounted in bottom of connection box of side of fan, note you may need to remove cover from socket before plug can be fitted.
Note: make sure plug is pushed fully home and fixing collar fully tightened when fitting.
4. Adjust damper flap fully down (FULL OVER FIRE AIR) manually by depressing clutch button and rotating using handle on the end of the drive shaft.

NOTE: Damper assembly must be removed or disabled when burning wood.

If damper assembly is removed the AIR DIVERTER PLATE should be re-set as per section “G” above (WOOD BURNING)

If damper is left in place turn DAMPER ON/OFF switch on main control box to OFF and adjust the damper manually to provide 20mm UNDER FIRE AIR as indicated by the RED line in the scale on side of the damper assembly

Line engraved in the end of the drive axle indicates the actual position of the internal damper flap



MANUAL ADJUSTMENT

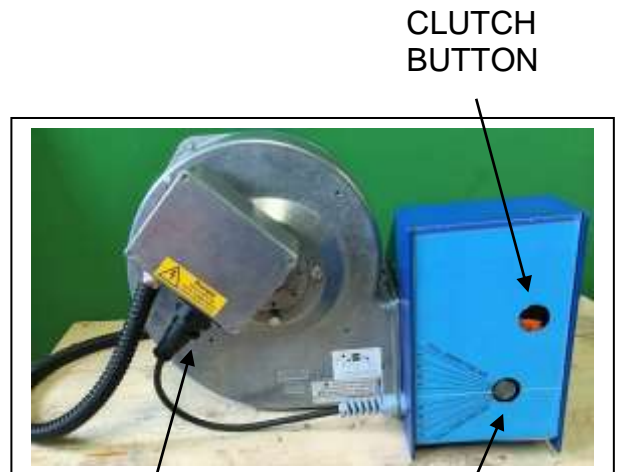

DAMPER PLUG/SOCKET

DAMPER SHAFT

DAMPER SCALE

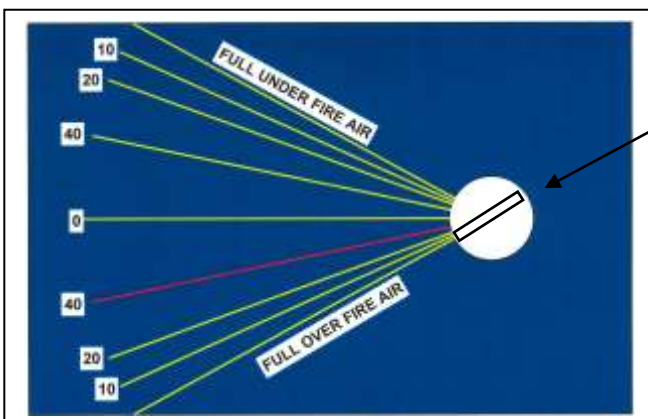

DAMPER BLADE POSITION MARKED ON DRIVE SHAFT

Scale indicates in mm position of damper blade.

0 indicates blade is horizontal, i.e. equal OVERFIRE and UNDERFIRE AIR

MOTORISED AIR DIVERTER ASSEMBLY – BB144/3R, BB146/3R and BB154/3R

1. Fix motorised damper assembly onto boiler door flange using 12x M8 nuts and bolts.

The damper has a horizontal fixed plate at one end of the damper assembly, this end is mounted next to the boiler door.

2. Fix fan to damper assembly using 4x M6 studs mounted on flange of damper assembly.
3. Plug damper assembly into 3 pin socket mounted in bottom of connection box of side of fan, note you may need to remove cover from socket before plug can be fitted.
Note: make sure plug is pushed fully home and fixing collar fully tightened when fitting.
4. Adjust damper flap fully down (FULL OVER FIRE AIR) manually by depressing clutch button and rotating using handle on the end of the drive shaft.

NOTE: Damper assembly must be removed or disabled when burning wood.

If damper assembly is removed the AIR DIVERTER PLATE should be re-set as per section “G” above (WOOD BURNING)

If damper is left in place turn DAMPER ON/OFF switch on main control box to OFF and adjust the damper manually to provide 40mm UNDER FIRE AIR as indicated by the RED line in the scale on side of the damper assembly

Line engraved in the end of the drive axle indicates the actual position of the internal damper flap.

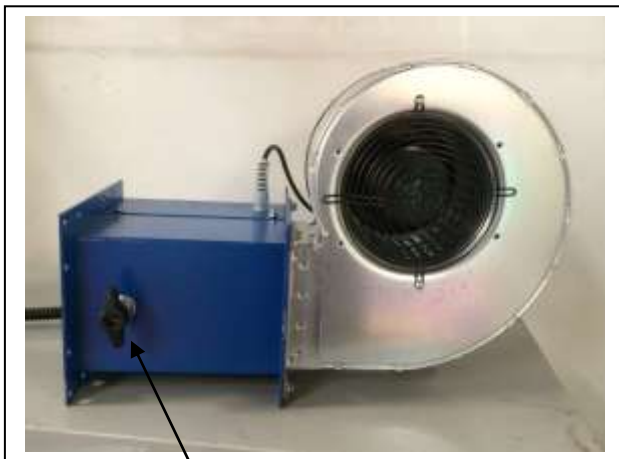

MANUAL
ADJUSTMENT

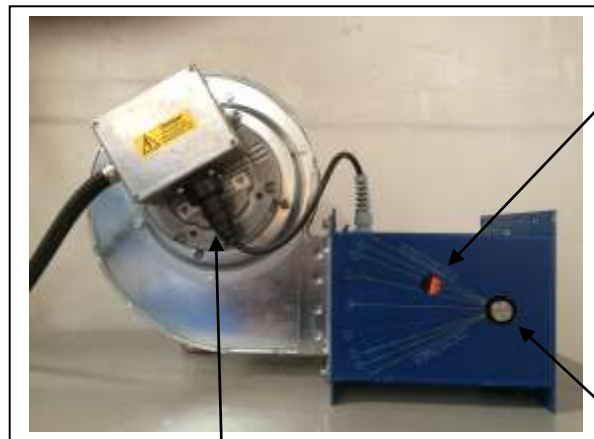

DAMPER
PLUG/SOCKET

DAMPER
SHAFT

CLUTCH
BUTTON

MOTORISED AIR DIVERTER ASSEMBLY – BB244/3R, BB254/3R and BB254H/3R

These boilers are fitted with 230V 3 phase fans.

1. Fix motorised damper assembly onto boiler door flange using 12x M8 nuts and bolts.

The damper has a horizontal fixed plate at one end of the damper assembly, this end is mounted next to the boiler door.

2. Fan and damper are supplied fully assembled and fitted with suitable plugs for connection to the main control cabinet.

***WARNING** - the fan/damper assembly weighs in excess of 30kG, care should be taken when fitting to avoid personal injury and/or damage to the assembly and connections.*

3. Fix fan/damper wiring loom to boiler and plug fan/damper assembly into respective sockets mounted in bottom of main control cabinet. *Note: make sure damper plug is pushed fully home and fixing collar fully tightened when fitting.*
4. Adjust damper flap fully down (FULL OVER FIRE AIR) manually by depressing clutch button and rotating using handle on the end of the drive shaft.

Line engraved in the end of the drive axle indicates the actual position of the internal damper flap.

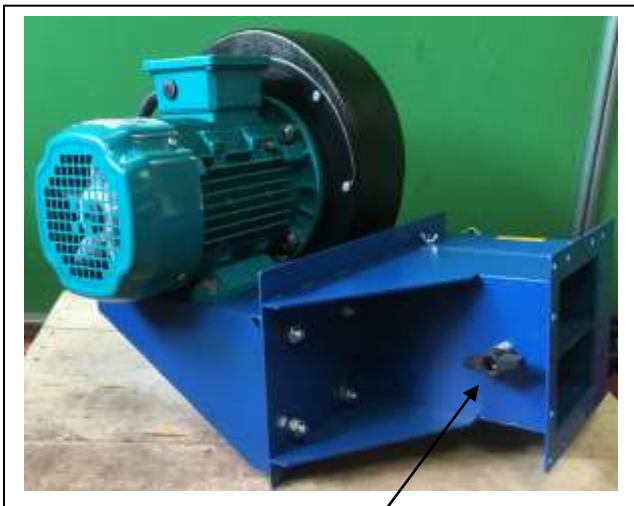

MANUAL
ADJUSTEMENT



DAMPER
SHAFT

CLUTCH
BUTTON

DAMPER AND FAN
CONNECTION PLUGS

NOTE: Damper assembly must be disabled and manually set when burning wood.

Turn DAMPER ON/OFF switch on main control box to OFF and adjust the damper manually to provide 40mm UNDER FIRE AIR as indicated by the RED line in the scale on side of the damper assembly

Line engraved in the end of the drive axle indicates the actual position of the internal damper flap.

REAR AIR SPREADER

Rear air spreader is not used when burning straw, if must be removed from boiler and the fitting in the base duct capped or plugged with the fittings supplied.

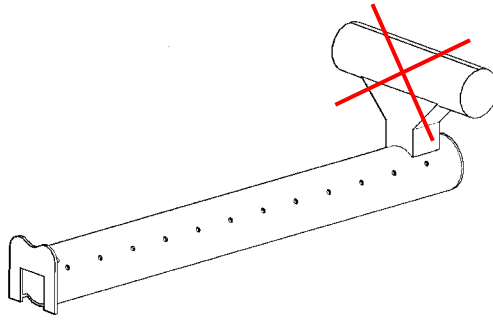

SECONDARY AIR DUCTING ON DOOR

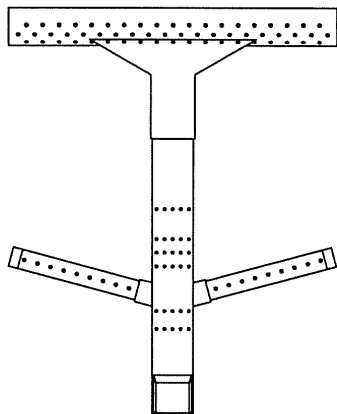

Secondary air is blown down onto the fire

and at the fire from lower down (lower air bars fitted to BB Boilers only)

As a general guide the lower Secondary air inlets should be directed approx. 30° to the vertical. On boilers with combustion chambers over 3000mm long, set at 35°.

They can be adjusted to suit but if turned to point too directly into the fire they will act more as Primary air than Secondary air which could cause the boiler to smoke.

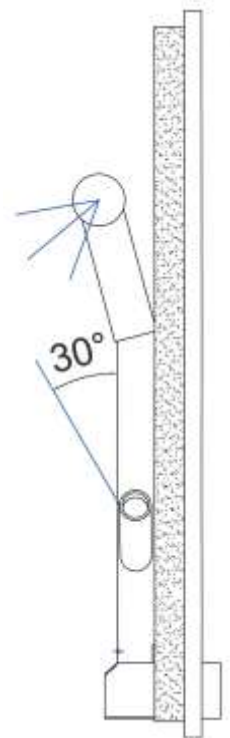
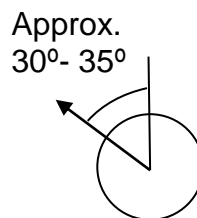

Note these parts are consumable items and may need to be replaced every 2 to 3 years

DAMPER OPERATION

TYPICAL SETTINGS	
HT70R HT80R BB144/3R BB146/3R BB154/3R	BB244/3R BB254/3R BB254H/3R
Damper Delay 30 min - 40 min	Damper Delay 30 min - 90 min
Soft Start 1 - 5 min speed 2 - 3	Soft Start 2 - 5 min speed 2 - 3
Fan Speed (after soft start) 5 - 8	Fan Speed(after soft start) 5 - 8
30 Mins	60 Mins
Damper travel complete	Damper travel complete
Approx. 75 min - 90 min from start	Approx. 120 mins to 180 mins from start
Fan speed 5 - 8	Fan speed 5 - 8
Combustion cycle will continue until period set on main timer has been completed, damper will then re-set to start position	Combustion cycle will continue until period set on main timer has been completed, damper will then re-set to start position

MOTORISED DAMPER OPERATION WHEN BURNING STRAW

After an initial delay, the damper gradually changes from all overfire air (secondary) to all underfire air (primary) over approx. 30 or 60 mins

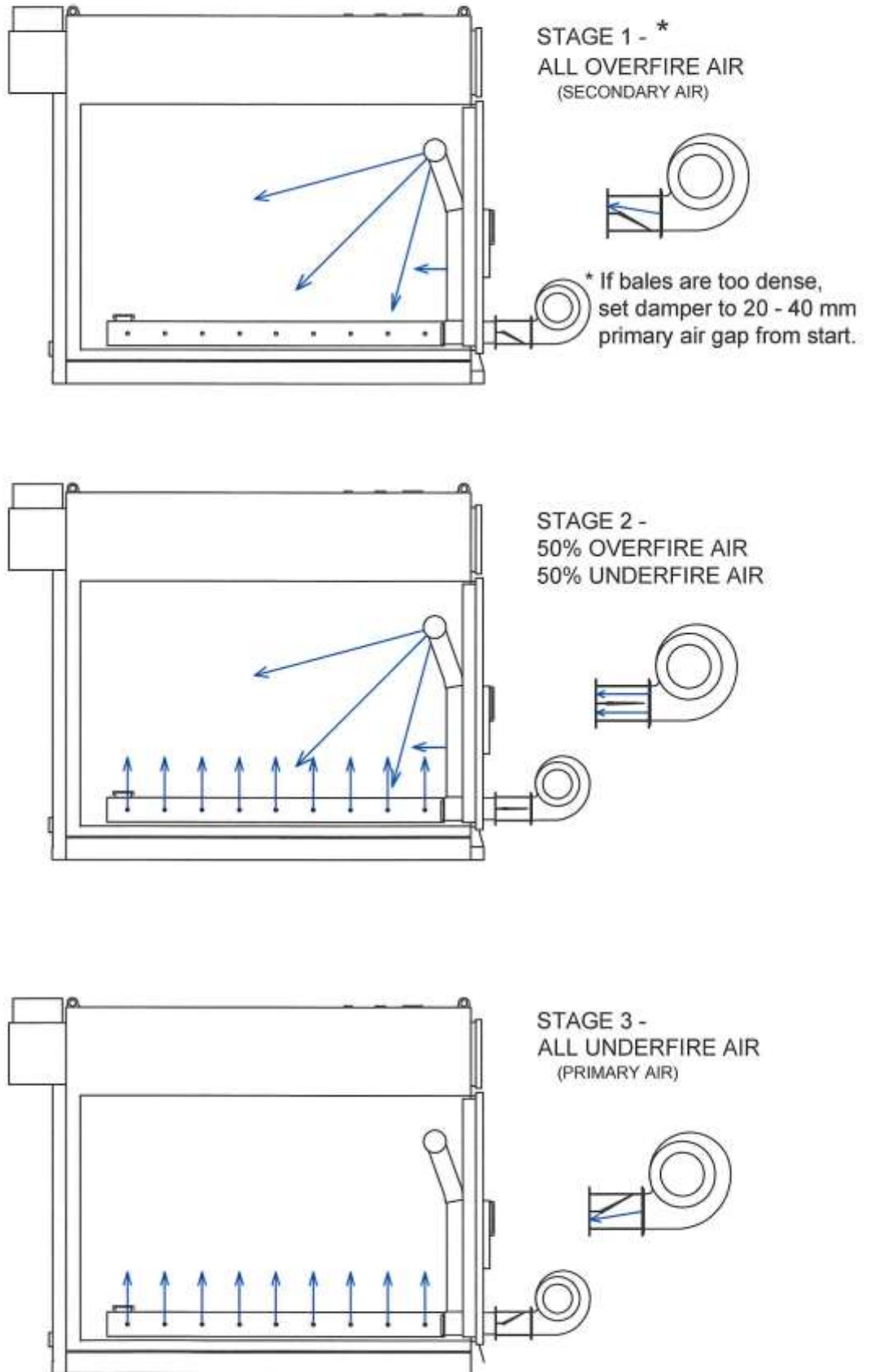

MOTORISED DAMPER SETTING WHEN BURNING WOOD

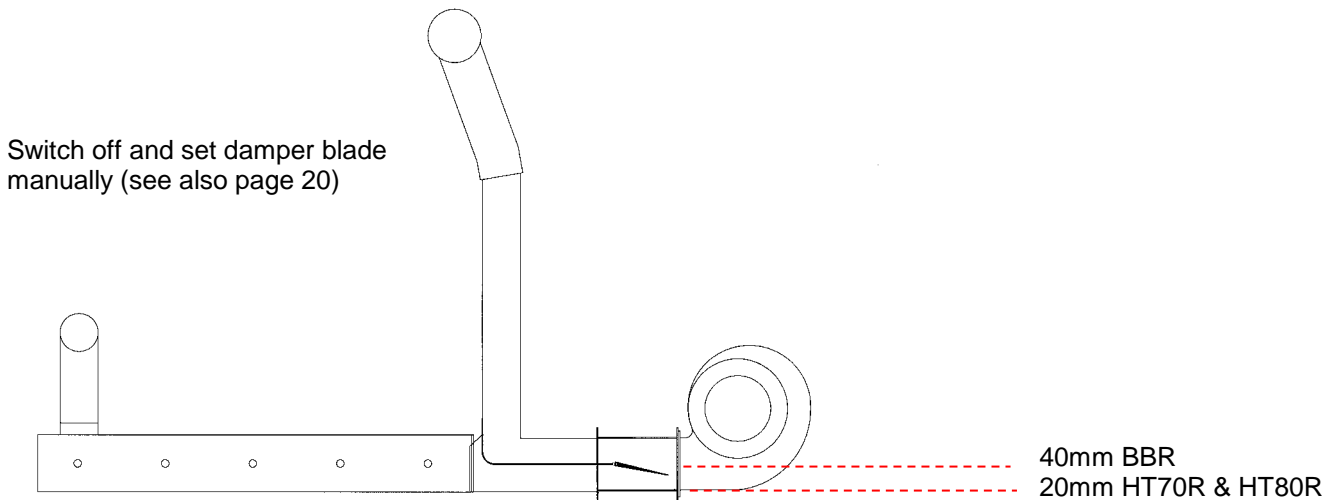

J. COMMISSIONING AND ROUTINE OPERATION OF THE BOILER

IMPORTANT NOTE: Before firing boiler, blow warm air onto the refractory side of the door for 3 – 4 hours. For first “light-up” create small wood fire at back of fire chamber using natural draft for at least 1 – 2 hours, (i.e. small stoker door open), repeat with slightly bigger fire, i.e. do not expose door to intense heat for first light-up.

Boiler should only be fired when accumulator and heat demand can absorb entire fuel charge, i.e. fan operates without interruption. Fuel should only be re-loaded when there is no fire or embers in boiler. However, if the fuel does re-ignite from embers at the back, always ensure that the fire is not smothered by fuel and that flame is well established at the front before starting fan. Failure to do so can lead to a build-up of smoke / un-ignited gases causing pressurisation and blowback.

When burning straw using the motorised damper mechanism initially all air is blown over the fire as secondary air (FULL OVERFIRE AIR). After approximately 1.25 to 2 hours the damper mechanism moves over a period of approximately 30 minutes to primary air (ALL UNDERFIRE AIR)

1. The system must be completely filled with water and all pumps working correctly.
2. Check temperature sensor is correctly located in ½” brass pocket in top of the boiler and plugged into boiler control box. In event sensor is not fitted (or if damaged) temperature controller (12) will display “OR”.

To ensure safe operation, if “OR” is displayed, OUT1 (fan) and OUT2 (pump) will default to an ON condition until the sensor fault is corrected.

3. Check base duct correctly positioned in chamber (entry gate plate in front of stops), so that air nozzle in door locates into square opening. Check secondary air spreaders are correctly mounted. For boilers with 2-piece base duct, ensure there is no gap between both sections.
4. Set control output (OUT1) to approx. 82°C. (When testing system on the first day, set it to 65°C. When it reaches this temperature and all is well, turn it up to 82°C.) Operating the boiler with control output (OUT1) set below 75/80°C can potentially cause boiler to idle for excessive periods resulting in tarring of boiler and heat exchange tubes, and eventual corrosion. **NOTE: OUT1 is factory set to 82°C**
5. Set Primary Pump output (OUT2) to approx. 75°C. (When testing system on first day, set to 60°C.) **NOTE: OUT2 is factory set to 75°C**
6. Set, and leave, boiler flue damper to fully open.

7. When BURNING WOOD

- Check rear air spreader is correctly located at rear of base duct.
- Check air diverter plate is correctly set (see page 17)
- *If damper mechanism is installed it **MUST be turned OFF** at control box and damper blade **MANUALLY** adjusted to 20mm UNDERFIRE AIR for HT70R & HT80R and 40mm for ALL BBR boilers.*
NOTE: Damper mechanism may be dismantled from the boiler when burning wood only.
- Set Soft Start period on Timer "F" in control box, initially set for 5 mins. Period may be reduced or extended as necessary to ensure good flame establishment
- Set Fan Speed 1 (Soft Start) on control box (7), initially set between 3 and 5.
- Set Fan Speed on control box (1). Usually set between speed 6 and 8.

8. When BURNING STRAW

- Check cap/plug has been fitted to rear air spreader mounting, no rear air spreader fitted.
- Check air diverter plate is correctly set (see page 17)
- Check damper mechanism is installed and turned ON at the control box.
- Adjust damper to **ALL OVERFIRE AIR**. (Denser bales may need 20-40mm primary air at start)
- Set damper delay on timer "G". For single bale boilers initial setting approx. 30-40 mins; for double bale boilers initial setting approx. 30-90 mins.
- Set damper operation cycle on Timer "H". The default settings operate the damper over an approx. 30 min period for HT70R-BB154/3R, and 60 mins for BB244/3R to B254H/3R. These have been found to be the optimum operation period for the damper mechanism. Before changing these value consult FARM2000
- Set Soft Start period on Timer "F" in control box, initially set for 2 mins. Period may be reduced or extended as necessary to ensure good flame establishment
- Set Fan Speed 1 (Soft Start) on control box (7), initially set between 3 and 5.
- Set Fan Speed on control box (1). Usually set between speed 6 and 8.

BURNING WOOD

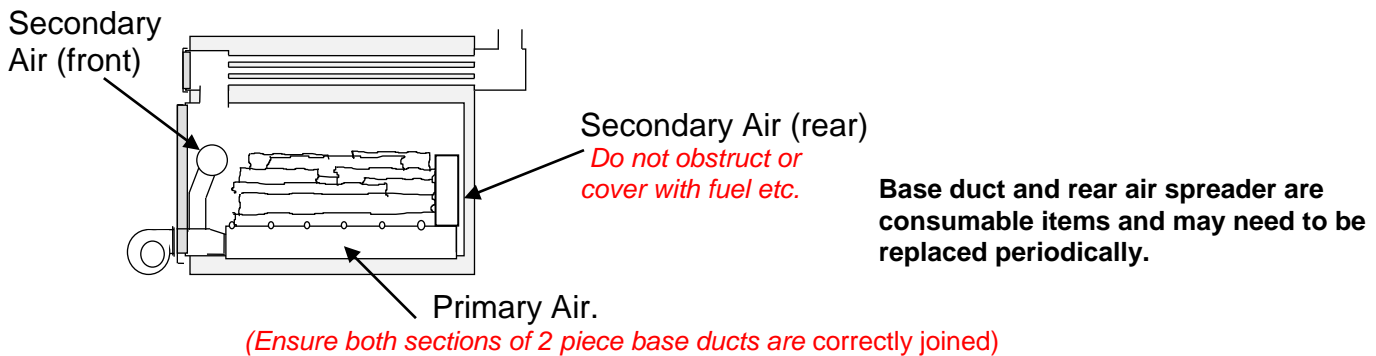

BURNING STRAW

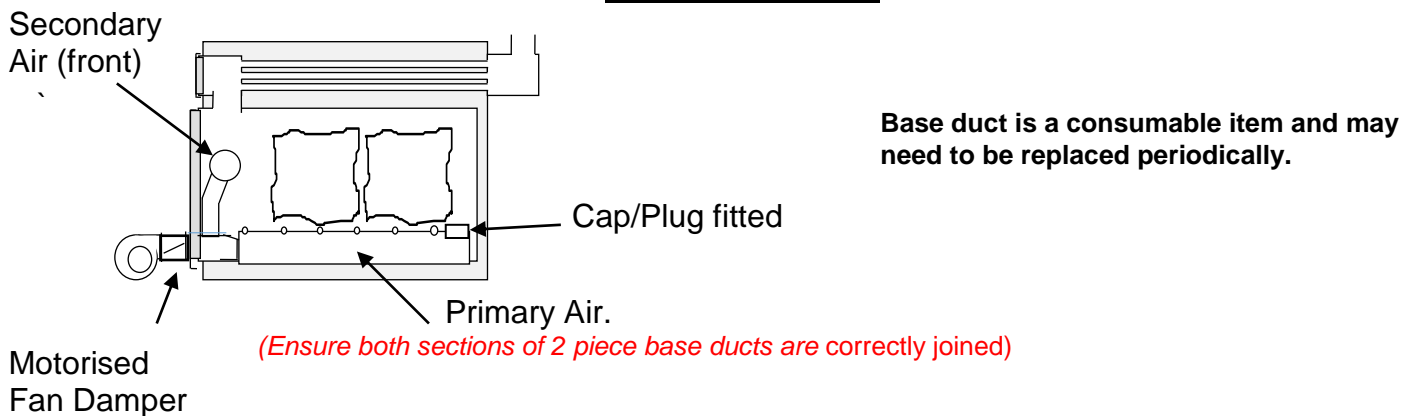

For summer use/periods of low output put less fuel in boiler. Do NOT allow to idle for long periods with boiler full of fuel.

9. Before lighting fuel in boiler, check that sufficient primary and secondary air is available inside combustion chamber (check through little stoker door) i.e. feel good airflow with hand.

10. Depending on fuel load, set fan timer switch to length of time the fan is required to operate. As a guide, set to 1 hour for every 25 - 50kg of fuel. The aim is to ensure the fuel is burned away and fan has stopped running for at least 2 - 3 hours before re-loading. Boiler will continue to provide a lower heat output for an hour or two after fan has stopped. Optimum setting is usually found within 2 - 3 days.

Setting the fan time for too long a period will result in blowing cold air into the combustion chamber which will cool boiler. If set too short it will result in un-burnt fuel being left in boiler.

11. Having loaded boiler (see drawing) with fuel, close main door and start fire at front of combustion chamber, through small stoker door/flap.
11. Before starting fan leave small door open for a short time until fire is established, then switch on fan, press timer reset button and then close small door. **It is essential to ensure good flame establishment before starting fan.** This takes longer with wood and with a cold chimney. Keep a check on the water temperature. **For fuel that "gasifies" quickly make sure the fire is never starved of air to prevent blowbacks.** If the fuel does not ignite readily, it is an indication of it not being dry enough.

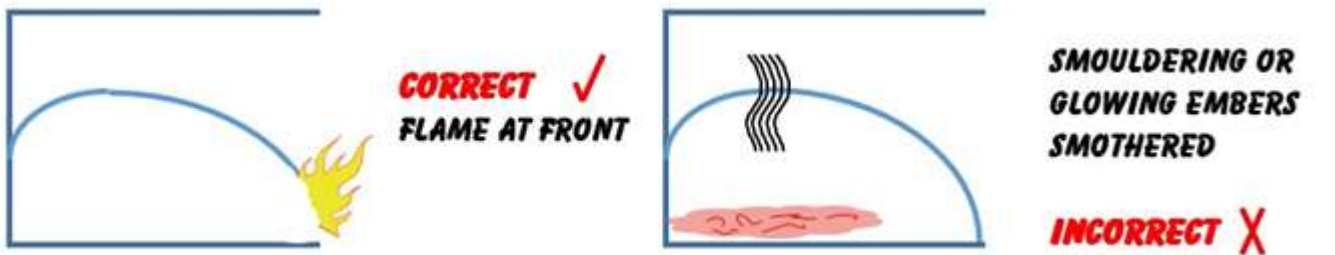

12. When required water temperature is reached, fan switches off and the 'water temperature' neon illuminates. As boiler cools, the fan restarts and fire is re-activated. Boiler should not be fired unless all or at least 75% of the fuel charge can be burned through without interruption. This cycle continues until time period set on the main timer has elapsed. Fan then switches off and 'timer off' neon illuminates. Temperature will gradually fall from 82/83°C to around 60°C, whilst the boiler continues to provide a (lower) output.
13. Flue damper should remain fully open most of the time. It is possible to make fuel savings by throttling the damper down but this should only be done **after** the fuel has burned for at least 2 hours and must **not** cause pressurisation of the combustion chamber. The damper **must** be opened again when boiler is reloaded. **If in doubt leave it open all the time.**
14. **IMPORTANT** When stoking/re-lighting boiler with fuel that quickly re-ignites, whether through main door or small stoker door, it is advisable **not** to close the small stoker door before starting fan, i.e. **open the small stoker door as you close main door, allow fire to establish with good flame formation at the front, start fan, press green button and then quickly close small stoker door.**
15. **IMPORTANT.** **When the green "home" light illuminates it takes approx. 90 seconds for the damper mechanism to re-set. In the event the GREEN TIMER RE-SET BUTTON is pressed before this re-set period has been completed OR the GREEN TIMER RE-SET BUTTON is pressed before the timer has finished, the damper mechanism must be manually re-set to ALL OVERFIRE AIR before the next combustion cycle is started.**
16. Operation with small stoker door open for more than a few minutes is dangerous and can cause overheating. The appliance must not be operated with the door left open after light up except as directed above.
17. The maximum amount of fuel specified in this manual should not be exceeded. Overloading will cause instability and smoke.

SAFETY NOTE:

- Do not open MAIN DOOR after light-up i.e. while fuel is burning
- Before opening the MAIN DOOR **always** switch the fan off.
- **HOWEVER**, the SMALL STOKER DOOR should **not** be opened after firing **unless** the fan is running. Failure to do this can result in a sudden ingress of air which can cause blow-back.

K. 24 HOUR THERMOSTATIC CONTROL WITH 5°C NIGHT SET-BACK

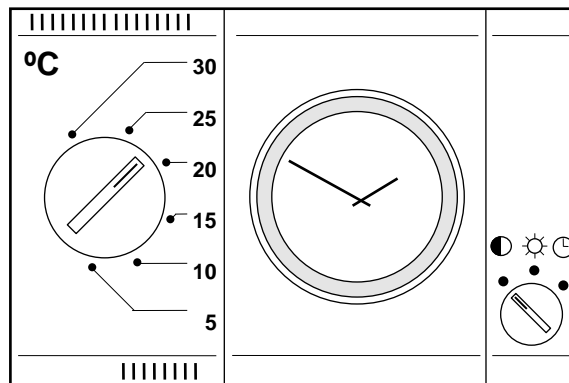

For every 1°C above 20°C that a house is heated, fuel consumption increases by 6%.

It is uneconomical (and uncomfortable) to overheat your house, particularly during the night, a control thermostat with time clock should be fitted in the house to regulate the required temperature by controlling the water circulation.

The ideal temperature control is a room thermostat with 24hr. time clock and night set-back facility. This lowers the pre-set temperature by 5°C (or more) automatically at required times during the day or night. In this way the structure of the house does not cool and a comfortable temperature is quickly re-established when required.

The room thermostat should be wired to the main circulating pump, or if a fully pumped system is used, to a motorised valve (see lay-outs). The boiler will usually feed the domestic hot water and primary system, on a continuous timed system.

L. SAFETY

1. Boiler room must be kept swept clean and free from fuel and combustible material. **A hose and fire extinguisher must be available at all times between the boiler and exit from the boiler room.**
2. **NEVER** leave the boiler unattended when the combustion chamber door or stoker door is open whilst it is alight.
3. Do not allow children into the boiler room.
4. Always take care when opening either the main or stoker door. Stand back and to one side; **do not peer into the combustion chamber.**
5. Ensure that the **fan is operating** when opening the small stoker door. **Do not** open within one hour of stoking the boiler, and **do not** open if there has been a failure in the power supply.
6. **Always** switch the fan off when opening the main boiler door.
7. When the control thermostat switches off the fan, the output of the boiler is reduced to a minimum; this should prevent overheating and the limit thermostat should switch on the main pump if the boiler still produces too much heat. On boilers without a limit thermostat, where overheating occurs, turn on the heating system and/or turn on the hot taps to cool the system. If necessary extinguish the fire using sand, soil or damp gravel - **do not use water.**
8. If water is lost from the system and the boiler while it is still hot **DO NOT TOP IT UP** - this could result in an explosion. Wait until the boiler has cooled down and call in a heating engineer.
9. The boiler is designed to operate at a water temperature of 80/85°C. It can be operated at up to 90°C provided there is adequate circulation.
10. The boiler must be fully drained if left in an exposed frosty condition unlit.
11. When cleaning ash out of the boiler a suitable dust mask should be worn. Dampen down with water if necessary. Take care that hot ash is disposed of safely.

12. Make sure the door is fastened open during stoking, so it cannot swing closed inadvertently.
13. Ensure that the chimney, flue box, heat exchanger tubes and area above the combustion plate are always kept clean. Failure to do this can cause a build up of pressure and possible blow-back when the door or stoker door/flap is opened. In certain circumstances it could even lead to an explosion.

The illustrated safety advice label is fitted on the boiler. If it has been removed or is illegible or damaged, then contact **Teisen Products** for a replacement.

SAFETY NOTICE
(in compliance with European 'Machinery Directive')

This boiler should only be operated by a competent person, familiar with the instruction book.

1. DO NOT leave boiler doors open if boiler is firing. This can cause a fire hazard.
2. Care should be taken when opening the boiler doors. Always open slowly.
3. DO NOT open small stoker door unless fan is operating. However, switch fan OFF when opening main door.
4. DO NOT open small stoker door in the event of power failure.
5. Beware of possible blow-back when opening small stoker door. DO NOT stand in front of stoker door when opening; stand back and to hinge side.
6. DO NOT peer closely into boiler.
7. Always close doors securely.
8. DO NOT STORE COMBUSTIBLE MATERIAL IN BOILER HOUSE.
9. Heat exchanger tubes, flue box and chimney must be kept clean.
10. Ensure flue damper is fully open when opening boiler doors.

Vertical Flue Spigot **Horizontal Flue**

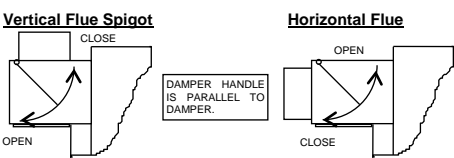

CAUTION: Flue box can become very hot. Combustible material and electrical wiring must be at least 500 mm. from flue box.

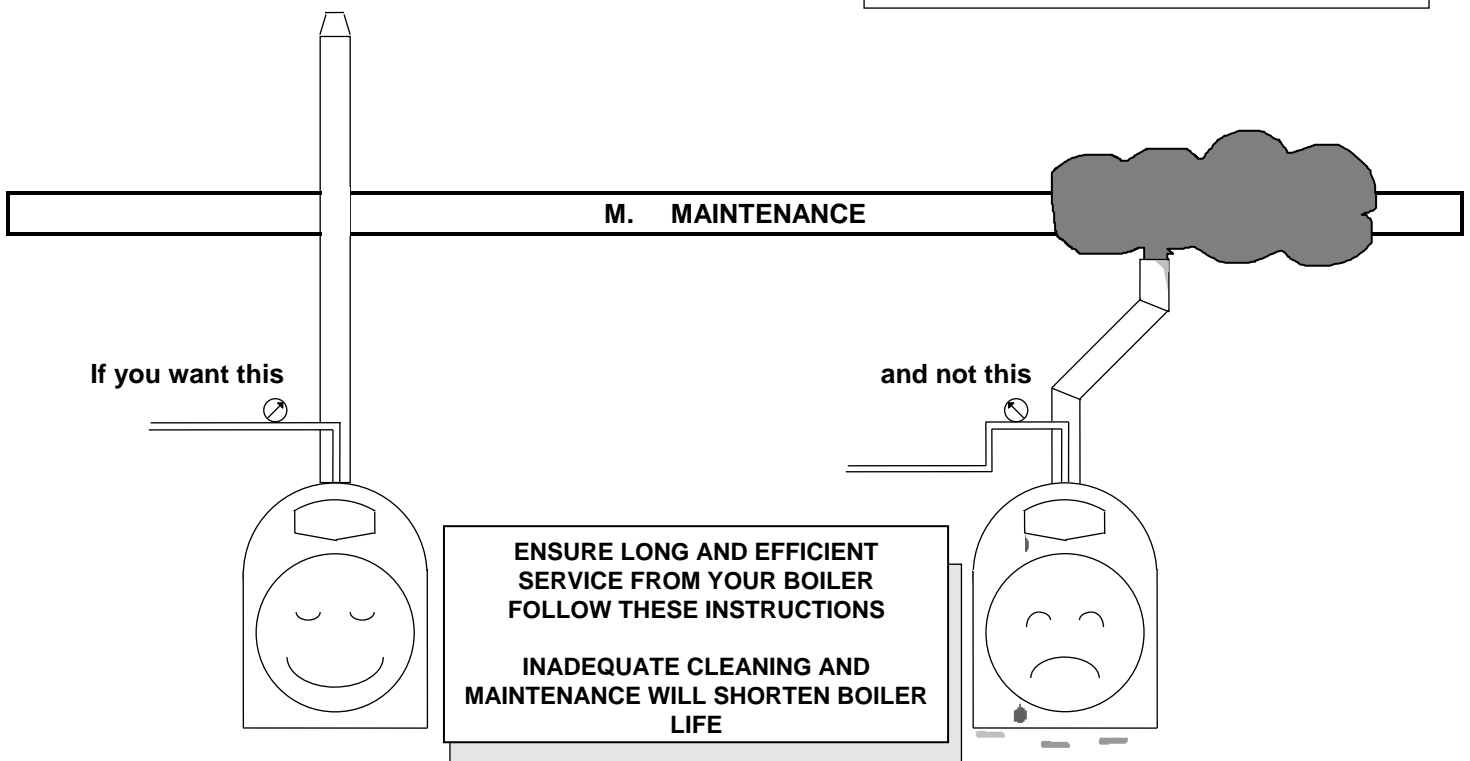

Combustion Chamber

Ash should be removed regularly from the combustion chamber. Ash builds up at a decreasing rate when using wood every 2-3 weeks is usually sufficient. A thin layer of **dry** ash can be left to improve combustion efficiency. When clearing the ash, check that there is no ash in the base and air ducts and that all holes are clear. Clean any deposits from combustion chamber walls. Dampen any hot ash before removing it.

In summer if the boiler is left un-used always clean out all ash deposits and make sure the boiler is ventilated. **When the boiler is operating, the temperature of the water jacket should always be kept above 60°C. The control thermostat should be set at 80/82°C or above. This will ensure minimal deposits within the combustion chamber and heat exchanger tubes. If the boiler operates at temperatures below this, condensation occurs leading to reduced efficiency, increased cleaning frequency and possible problems with boiler corrosion. The hotter the water temperature, the cleaner the boiler!**

Heat Exchanger Tubes

Inspect and clean the heat exchanger tubes regularly; the frequency of cleaning will vary from 1-2 weeks depending upon the fuel. Cleaning the tubes is easier if carried out at regular intervals and when the boiler water jacket is at 70°C or above.

Light deposits can be removed by the wire brush. For heavier deposits use the scraper, rotating it 180° to pull the deposits to the front where they will drop into the combustion chamber. When using the scraper, clean in stages working towards the flue box.

Flue Box

The flue box must be inspected and cleaned out regularly at 3 – 4 week intervals, using a vacuum cleaner, brush or thick glove.

Chimney

Chimneys must be inspected and cleaned at minimum twice per year to ensure adequate draught (i.e. suction) is always available. Even a small layer of deposits will restrict gas flow thereby reducing efficiency and causing the boiler to smoke.

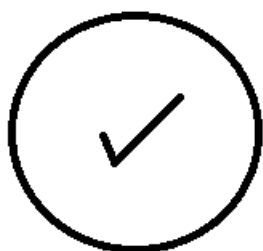

Correct

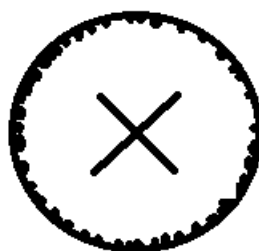

Not acceptable

Pay particular attention to the chimney after prolonged periods at low outputs, i.e. before the winter season begins. If the chimney is allowed to become dirty or partially blocked the resultant decrease in draught will impair combustion efficiency and can, in certain circumstances, cause blow-backs or even a small explosion! It can also lead to corrosion of the boiler.

Use a **stiff polypropylene** brush for cleaning stainless steel chimneys (available from **M&K Products**.) If the chimney and flue box are not kept clean, corrosion can occur.

Fan and Fan Damper

Isolate the fan from the mains and inspect the fan impeller when required. To clean the blades remove the fan guard and carefully brush away deposits with a small brush. If the boiler is operating in a dusty environment the fan should be cleaned more frequently.

Inspect the inside of the fan damper (when fitted) and air ducting at regular intervals; remove any deposits and scrape the sides clean. It is essential that there is always adequate secondary air. Use a counter-sink drill, or wire brush, occasionally to clear the holes on the air spreaders.

Main Door Bearings (Big Bale Boilers only)

Main door bearings on big bale boilers should be greased, via grease nipples fitted, at a minimum of 3 monthly intervals.

Boiler out of operation (i.e. summer)

If the boiler is not being used, thoroughly clean out the combustion chamber and heat exchanger tubes and switch off the mains supply to the control unit. Allow the combustion chamber to be ventilated by leaving the stoker door/flap slightly open and the flue damper fully open. If ash is allowed to lie in the boiler for too long, corrosion can occur.

Make sure the boiler is isolated from any source of warm water when not in use.

Seals

Inspect the seals on the flue access plate, manifold cover, main door and small stoker door/flap and check for wear; adjust the door catch if necessary to ensure an airtight seal. Replace every 2 – 3 years. Replacements are available from **M&K Products Ltd**

N. CONTROL BOX WIRING DIAGRAMS

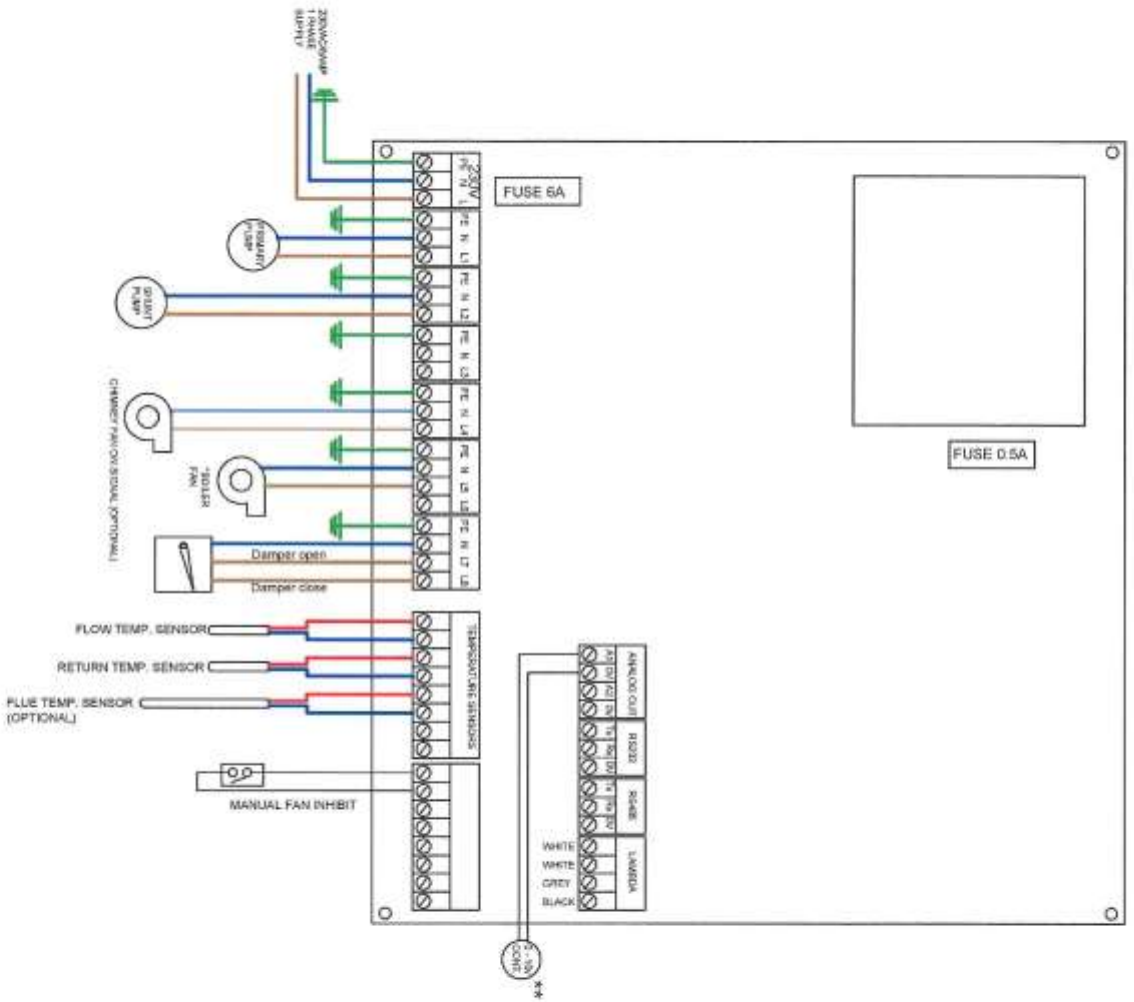

Note: Maximum total output must not exceed 6 amps.

For larger capacity Primary Pumps etc output should be "slaved" through a suitable 230V/50Hz relay.

* connect only single speed 230VAC/50Hz fans directly to L5

** fans utilising 0-10volt output for speed control must be supplied with direct 230VAC/50Hz supply and not via L5

FARM2000

MAK PRODUCTS (BROOKS) LTD
 Dodder, Birmingham, Warwick, B81 8BT
 Tel: 01273 821021 Fax: 01273 821066

The original of this drawing is the exclusive property of MAK Products Ltd and the acceptance of this print constitutes an agreement that it will be treated as a confidential document to be used for no other purpose other than aid in the assembly or operation of MAK Product's equipment or as otherwise expressly authorized by MAK Products Ltd. These drawings are not to be communicated, disclosed, copied or published except as expressly authorized in writing by MAK Products Ltd.

No.	DATE	ALTERATION

TITLE	TLS	DATE	MATL	SCALE
TS2 - ELECTRICAL CONNECTION DIAGRAM	TLW	11/16		NLS

USED ON	DRG. NO.
HT36, HT48R, HT50R, HT60R, HT70R, HT80R, BB144/3R, BB146/3R & BB154/2R	TS2

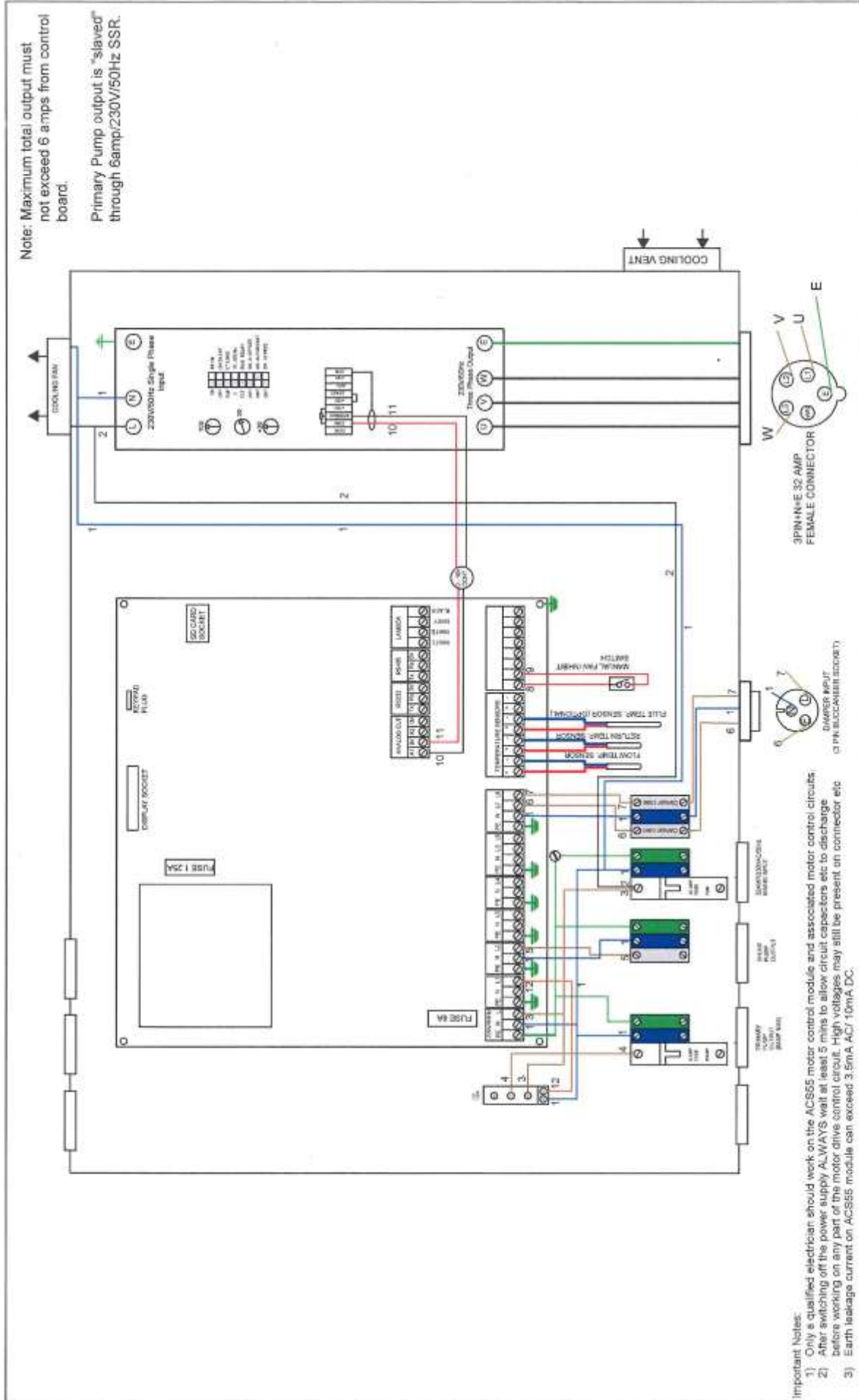

Important Notes:

- 1) Only a qualified electrician should work on the ACS55 motor control module and associated motor control circuits
- 2) After switching off the power supply ALWAYS wait at least 5 mins to allow circuit capacitors etc to discharge before working on any part of the motor drive control circuit. High voltages may still be present on connector etc
- 3) Earth leakage current on ACS55 module can exceed 3.5mA AC/ 10mA DC.

<p>FARM2000 M&K PRODUCTS (BROMSDEPHEVE) LTD Dodder, Bromsgrove, Woxs, B61 8BT Tel: 01527 821821 Fax: 01527 821865</p>	<p>The original of this drawing is the exclusive property of M&K Products Ltd. and the acceptance of this print constitutes an agreement that it will be treated as a confidential document to be used for no other purpose other than aid in the assembly or operation of M&K Products equipment or as otherwise expressly authorised by M&K Products Ltd. These drawings are not to be communicated, disclosed, copied or published except as expressly authorised in writing by M&K Products Ltd.</p>		<p>USED ON BB244/3R, BB254/3R & BB254H/3R</p>
	<p>TITLE TS2E - ELECTRICAL CONNECTION DIAGRAM</p>	<p>DRAWN TLW</p>	<p>DATE 11/16</p>
<p>NO.</p>	<p>DATE</p>	<p>ALTERATION</p>	<p>DRG. NO. TS2E</p>