

FARM 2000 HTR Range (when fired on WOOD only)

M&K PRODUCTS (BROMSGROVE) LTD, DODFORD, BROMS, WORCS, B61 9BT. ☎(01527) 836444 ✉heat@farm2000.co.uk

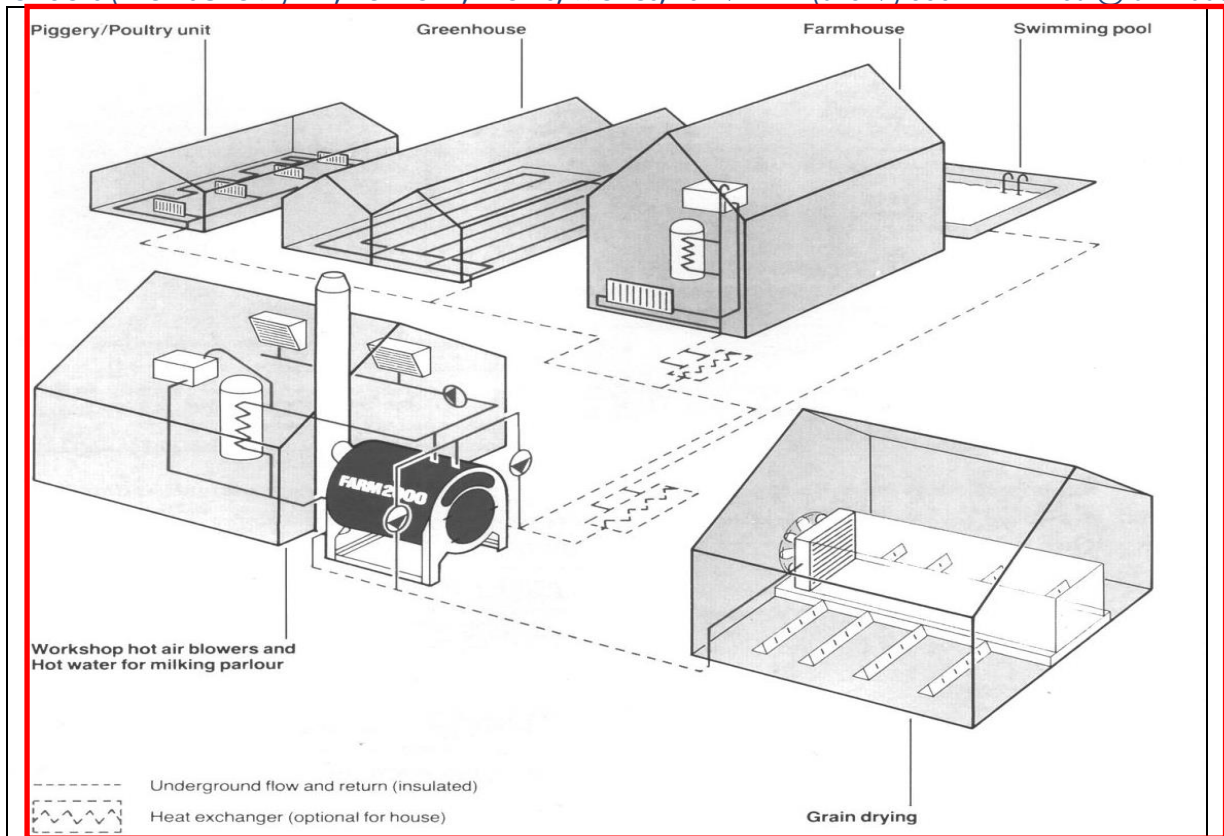

INSTALLATION AND OPERATING INSTRUCTIONS FOR FARM 2000 HTR BOILERS (WOOD only)

A.	IMPORTANT INFORMATION	2.
B.	INTRODUCTION	3.
C.	WOOD - GENERAL USE	3.
D.	GENERAL NOTES ON SITING AND INSTALLATION	3.
E.	CHIMNEY	5.
F.	PLUMBING	8.
G.	ACCUMULATORS	9.
H.	TS3 FAN CONTROL UNIT	14.
I.	ASSEMBLING AND SETTING OF BOILER COMPONENTS	22.
J.	COMMISSIONING AND ROUTINE OPERATION	23.
K.	24 hr. THERMOSTATIC CONTROL WITH 5°C NIGHT SET-BACK	25.
L.	SAFETY	25.
M.	MAINTENANCE	26.
N.	WIRING DIAGRAM	28.
O.	TROUBLE SHOOTING GUIDE	29.

See www.farm2000.co.uk for typical installations and video of boiler operation.



A. IMPORTANT INFORMATION – BEFORE you begin

Retention of this Instruction Book

This Instruction Book must be kept handy for reference as it contains important details on the safe and proper use of the boiler. Read carefully and understand the following instructions before proceeding with the installation and operation of the boiler.

WARNING! DANGEROUS VOLTAGE



- Only a competent, suitably qualified electrician should install a FARM2000 Fan Control Unit
- Fan Control Unit must be wired via a double pole switched fuse or plug and socket. This supply must not be connected through a time switch or other control device.
- Cabinet should be fixed in position before MAINS connection [230V AC 50Hz/ 16AMP MAX]
- Care should be taken when adjusting internal timer functions as MAINS is present in the cabinet
- Fan Control Unit should not be exposed to water

Visual check on the condition of the Control Box and exposed electrical cables should be undertaken on a daily basis before lighting the boiler. Should the Control Box be distorted by heat or any wiring potentially exposed to fire/melted, the Control Box should be isolated from MAINS supply and a qualified electrician sought.

WARNING! BOILER SHOULD ONLY BE OPERATED BY A COMPETENT PERSON FAMILIAR WITH THIS INSTRUCTION BOOK



WARNING

- Boiler room must be well ventilated, kept swept clean and free from fuel and combustible material. A hose and fire extinguisher must be available at all times between the boiler and exit from the boiler room.
- NEVER leave the boiler unattended when the combustion chamber main door or small stoker door is open whilst it is alight.
- Do not allow children into the boiler room
- Boiler should only be fired when accumulator and heat demand can absorb entire fuel charge, i.e. fan operates without interruption. Fuel should only be re-loaded when there is no fire or embers in boiler. However, if the fuel does re-ignite from embers at the back, always ensure that the fire is not smothered by fuel and that flame is well established at the front before starting fan. Failure to do so can lead to a build-up of smoke / un-ignited gases causing pressurisation and blowback.
- Always take care when opening either the main or stoker door. Stand back and to one side; do not peer into the combustion chamber.
- Ensure that the fan is operating when opening the small stoker door. Do not open within one hour of stoking the boiler
- Do not open small stoker door if there has been a failure in the power supply.
- Always switch the fan off when opening the main boiler door.
- In the event of a power failure, where overheating occurs, turn on the heating system and / or turn on the hot taps to cool the system. If necessary extinguish the fire using sand, soil or damp gravel - do not use water.
- If water is lost from the system and the boiler while it is still hot **DO NOT TOP IT UP** - this could result in an explosion. Wait until the boiler has cooled down and call in a heating engineer.
- Ensure that the chimney, flue box, heat exchanger tubes and area above the combustion plate are always kept clean. Failure to do this can cause a build-up of pressure and possible blow-back when the door or stoker door is opened. In certain circumstances it could even lead to an explosion.
- Make sure the door is fastened open during stoking, so it cannot swing closed inadvertently.
- When cleaning ash out of the boiler a suitable dust mask should be worn. Dampen down with water if necessary.
- Appropriate gloves should be worn when handling hot ash or boiler parts
- The boiler must be fully drained if left in an exposed frosty condition unlit.



CAUTION

- Make sure that hot ash is disposed of safely.
- A safety advice label is fitted on the boiler. If it has been removed or is illegible or damaged, then contact Teisen Products for a replacement.

B. INTRODUCTION

Your **FARM 2000 BOILER** is a sound investment which will provide low cost heat for many years. To ensure the best operation of your boiler and long service, **we strongly recommend that you follow these instructions closely. Incorrect installation and operation of the boiler will reduce its service life.**

If you have any boiler problems that cannot be answered from this instruction book, please contact **Teisen Products** direct. **Teisen Products** supply suitable chimneys.

These instructions apply to the **FARM 2000 HTR range**

Wearing/Service Parts: Please be aware that steel air distribution parts used in the combustion chamber may need replacing every 2 – 5 years depending on fuel being used and boiler operation. Insufficient air, premature idling or use of some waste woods may shorten their life.

C. FUEL – GENERAL USE

FARM 2000 HTR boilers are certified for RHI on logs straw only (check specific boiler details for acceptable fuels). They are not suitable for burning fossil fuels such as coal, coke, oil or gas. At the same time, use of industrial waste wood or contaminated wood is not acceptable for RHI use, and can also cause boiler corrosion.

Efficient operation can only be achieved with dry fuel. Emissions and outputs are based upon moisture contents up to 20% for wood and 17% for cereal straw. Levels above this will reduce outputs and efficiency, may cause incomplete combustion (producing smoke), and increase ash and deposits in the boiler and chimney. Excess moisture can also cause corrosion.

WOOD - should be felled before spring, stored for at least 2 years, and be under a roof for at least 6 months before the winter of use, somewhere where the wind can get at it, but not the rain.

DO NOT BURN TYRES, PLASTICS, RUBBER ETC, OR ANY FORM OF FOSSIL FUEL. THIS IS NOT ONLY DANGEROUS BUT WILL DAMAGE THE APPLIANCE AND INVALIDATE ANY WARRANTY CLAIM.

D. GENERAL NOTES ON SITING AND INSTALLATION

FOR DETAILS ON CHIMNEY AND PLUMBING, SEE SECTION E and F.

The following criteria apply when choosing a site for the boiler:

1. Ease and convenience of fuel handling. Fuel must be stored under a roof **adjacent** to the boiler room, **not in it**.
2. The boiler should be installed external to the dwelling area.
3. Site the boiler where a suitable chimney can be erected, or an existing chimney utilised (*See Section E*)
4. The boiler should be positioned so the cold feed and open vent are protected from frost, and where there is some form of gravity heat leak (*See Section F & G*).
5. The boiler can be installed remote from the heated requirement, with insulated underground pipework *provided an accumulator is installed next to the boiler, or that there is some form of heat leak.*

Boiler should be installed according to this booklet and the following;

- The boiler must be installed in a fire-proof boiler room, which should NOT be an integral part of a domestic dwelling.
- The boiler must only be installed by a competent heating engineer.
- The boiler, chimney and system should be installed in compliance with current relevant Building Regulations and B.S. Codes of Practice for solid fuel appliances, flues and chimneys
- All electrical work should be carried out to current I.E.E. Standards.
- The installation should conform to Local Authority and Water Board Regulations.
- There must be no valves in the cold feed or open vent.
- The boiler should be under cover, fully protected from the weather, with adequate ventilation for the boiler at the rate of 1 sq. ft. per 250,000 BTU/hr. (0.12m² per 100 kW).

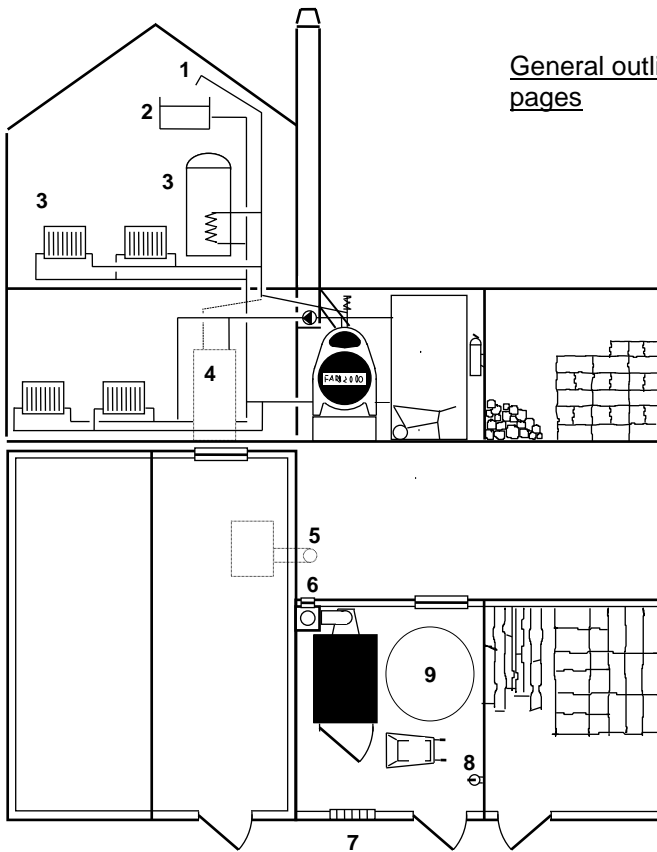

General outline installation for reference only . For full details see later pages

1. Open Vent.
2. Cold feed and expansion.
3. Gravity circuit.
4. Existing oil/gas fired boiler (optional) (pumped circuit)
5. Separate chimney for existing boiler.
6. Access for chimney cleaning.
7. Ventilation at floor and ceiling level.
8. Fire extinguisher.
9. Accumulator tank

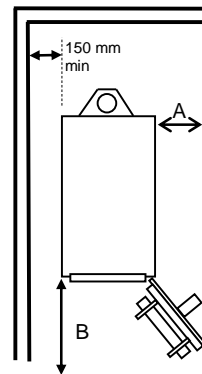

Recommended minimum boiler clearances from walls etc to allow correct opening of boiler door and allow full access when stoking.

	A	B
HT36/46	550mm	850 mm
HT50	625mm	1020mm
HT60/70/80	770mm	1380mm
BB144/BB146	1230mm	1770mm
BB244		
BB154/BB254	1380mm	2050mm

Min 150mm clearance on non-hinged side of boiler on all models.

- The boiler must be on a level concrete or brick surface. For Big Bale Boilers ensure the door cannot swing closed by gravity, and arrange for the door to be secured whilst stoking. Big Bale Boilers should be installed in their final position and the door checked before plumbing. If it is felt the door can swing closed, the rear of the boiler can be shimmed up to provide a more neutral action.
- HT boilers should be raised by approx. 300 - 400mm on a plinth to suit wheelbarrow. This makes stoking and de-ashing easier.
- There must be good access to the rear of the boiler for cleaning the flue box and chimney.
- Allow clearance in front of the boiler for tube cleaning (i.e. length of combustion chamber plus, at least 100 mm.)
- There should be no combustible material in the boiler room, which should be constructed from non-combustible materials.
- There should be a fire extinguisher and water hose accessible from the boiler and boiler room door.

NOISE LEVELS

The following airborne noise level data applies to FARM 2000 HTR boilers; at 1m. from free blowing fan (A-weighted sound pressure level, dB(A) reading) This is given in order to comply with the European 'Machinery Directive'.

HT46R (G2E-120 2µF fan)	53 dB(A)	HT50R (G2E-140 2µF fan)	53 dB(A)
HT60R (G2E-140 2µF fan)	53 dB(A)	HT70R (G2E140 4µF Fan)	67 dB(A)
HT80R (G2E180 fan)	75 dB(A)		

E. CHIMNEY

The boiler's efficiency and output are dependent on a well designed chimney. The two functions of a chimney are to disperse the exhaust gases, **and** to provide adequate draught through the boiler so the fuel always burns under a negative pressure. Failure to achieve this results in inefficient combustion, a dirty boiler and boiler corrosion. It can also cause dangerous blow-backs during operation.

The chimney should rise vertically from the boiler flue spigot, preferably with no bends or elbows, and its minimum height from the flue box spigot is shown below: Boiler life will be significantly reduced if these recommendations are not followed.

The chimney is made up from sectional lengths and is **not** self supporting. It must be secured to a wall (if sufficient height is available) or to a steel mast as shown. Chimney support mast to be sourced locally.

To test chimney draught (do this when boiler and chimney are warm), open the small stoker door when there is a fire in the boiler, and if smoke emits continuously, the draw is likely to be inadequate.

We strongly recommend a straight chimney without bends for best performance and prolonged boiler life.

BOILER MODEL	MIN. LENGTH H (M)
HT46R	5.5
HT50R	6
HT60R	6
HT70R	7.5
HT80R	9

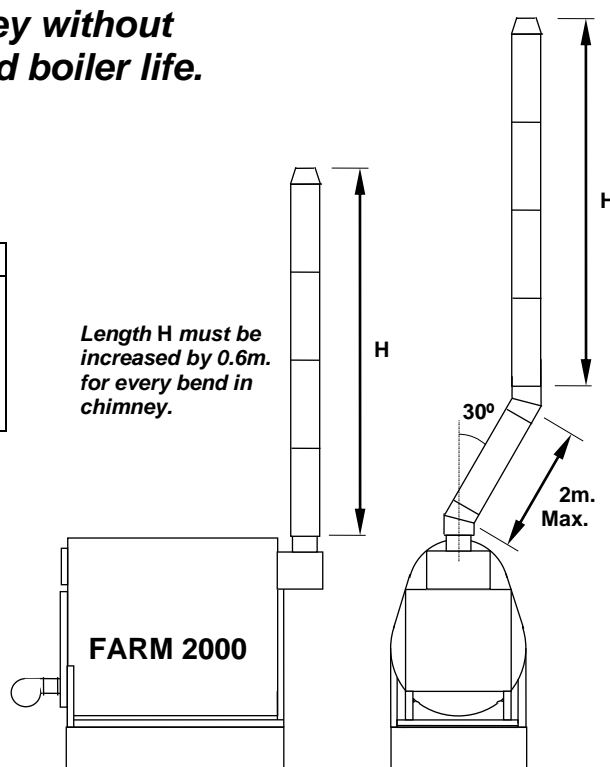

* all angles quoted to the vertical

The Chimney must be higher than surrounding buildings and be insulated to the top, to prevent cooling of the flue gases.

There must be no horizontal lengths of flue pipe and, if the boiler is being connected to an existing brick chimney, this should be via a 30° elbow*; only if space does not permit should a 45° elbow* be used. If a chimney has to be routed round an obstruction use 15° or 30° elbows*. There must never be more than **two** elbows in a chimney.

Ensure that all of the chimney can be swept.

The most suitable chimney is sectional, insulated (50mm thickness), twin wall stainless steel. This type of chimney provides a better draught than a brick chimney, and is easier and less costly to install.

If an existing brick chimney is to be used, ensure that its internal dimensions and height are adequate, it is properly insulated and can be easily swept. The connecting flue pipe should be insulated.

Chimney pots and chimney caps should not be fitted. The chimney must only serve one appliance.

STAINLESS STEEL INSULATED CHIMNEY
(can be supplied colour powder coated to suit)

This is not a working drawing and is for guidance only. Details of mast specification, foundation, supports and chimney should be checked by installer, taking local conditions and building regulations into account.

Chimneys must have 50mm of insulation						
Internal Diameter (mm)		175	200	250	300	350
A	Maximum length of chimney boiler can support (m)	7	6	7	4	4
B	Maximum length of unsupported chimney (m)	1.7	1.7	1.7	1.7	1.7
C	Recommended max. distance between Brackets (m)	3	3	2	2	2
D	Maximum length of chimney above an intermediate vertical support (m)	8	8	7	6	5

Chimney Diameter **must not be less** than the the boiler flue spigot diameter.

CHIMNEY MAST SECTION GUIDE	
Chimney Height above ground (m)	R.H.S. Section *
8.1m	150 x 150 x 8
9.1m	180 x 180 x 8
10.6m	200 x 200 x 10
11.3m	250 x 250 x 8
12.6m	250 x 250 x 12.5

*This section can be reduced in sheltered areas or if part of chimney is inside building.

If the 50 mm insulated chimney passes through, or near, a wall or ceiling, the outer skin must be at least 100 mm from any combustible material. For extra protection fit a stainless steel heat shield sleeve in front of any woodwork. **Uninsulated** (single wall) flue pipe must have at least 500 mm clearance **and** a heat shield

Further information on chimney, mast and mast foundation available on request.

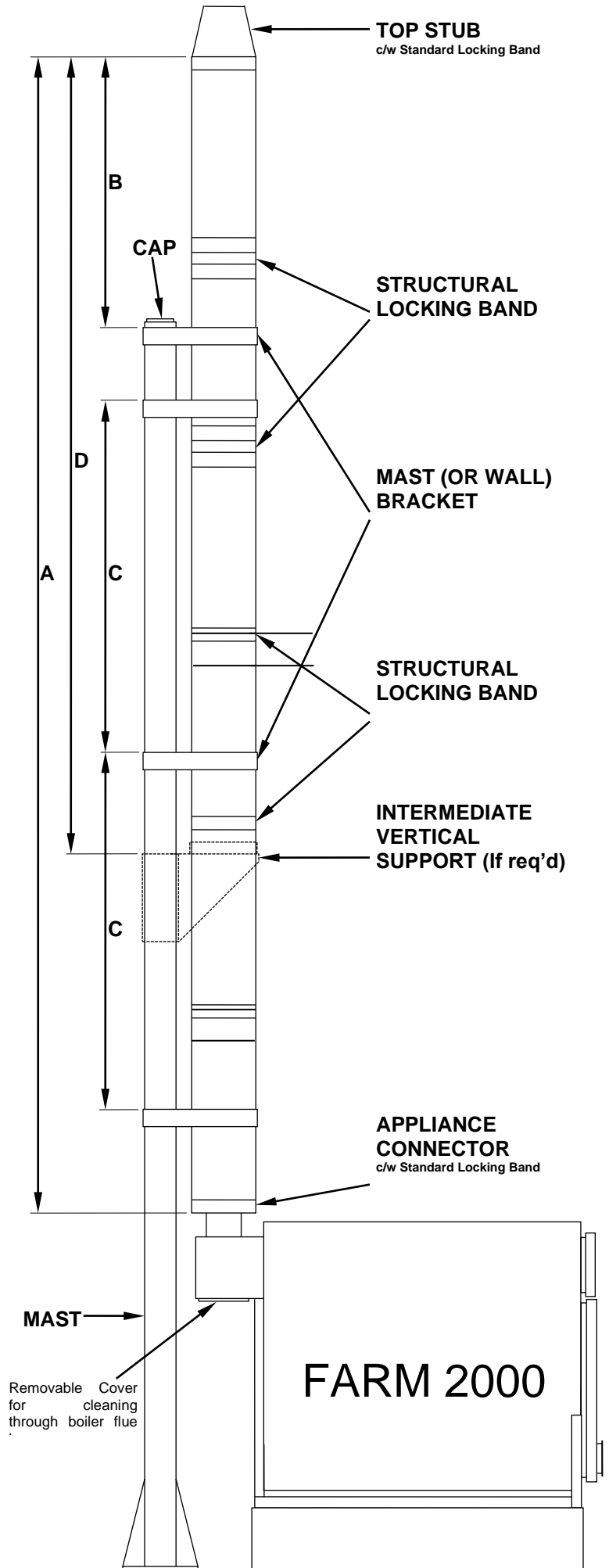

See drg. 410/1

BRICKWORK

NOTE:-

THIS DRAWING IS FOR REFERENCE ONLY.

FOR COMPLETE SPECIFICATION USE S.F.A.S. BOOKLET "DOMESTIC MASONRY CHIMNEYS" AND BUILDING REGULATIONS.

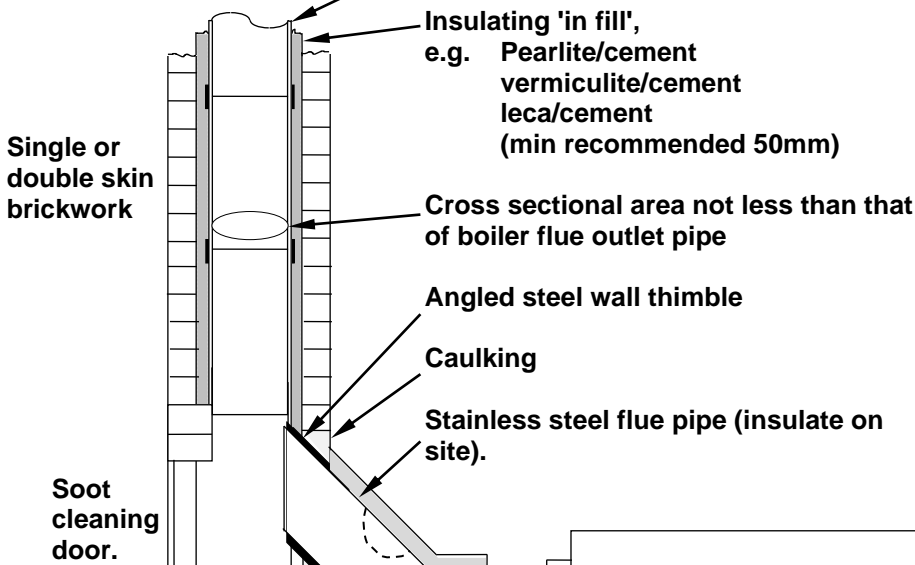
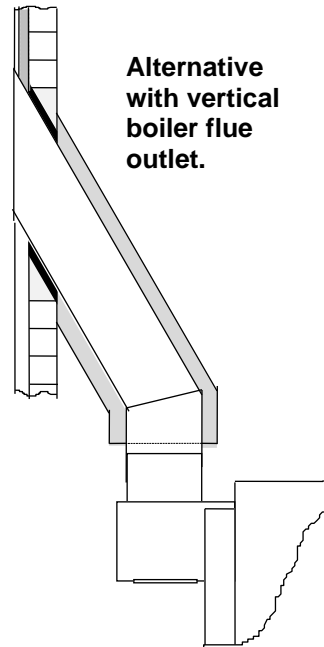
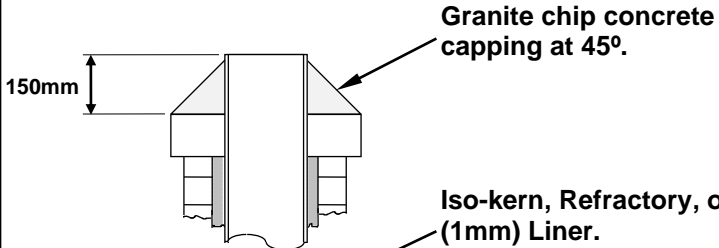
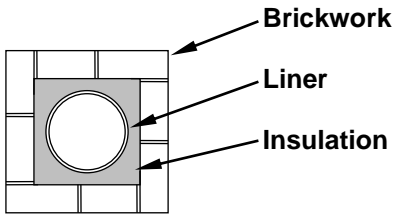

Clean out access panel

Allow length of comb. chamber plus 100mm. min. clearance for tube cleaning rods.

FARM 2000

Clear area for fuel access.

300 - 500mm

Concrete plinth or brickwork to raise boiler to desired stoking height. *BB Boilers NOT to be raised

F. PLUMBING (Including Accumulators)

The **FARM 2000 HTR** Boilers range is a Low Temperature Hot Water Boiler (LTHW), and should only be fitted to open vented, indirect heating systems, via an accumulator tank.

In addition to the guidelines given under Section B, the following requirements must be observed:-

- Boiler must always have its own separate cold feed and open vent pipes.
- Open vent, **which must have a continual rise**, must always discharge into the feed and expansion tank.
- There should be no valves in the cold feed or open vent. (If valves are fitted, the handles must be removed, labelled and the operator clearly instructed. Operating a boiler with a valve closed can be highly dangerous.)
- All pipework should be black iron (medium gauge) or copper. Fittings must be able to withstand boiling water

The table below shows minimum sizes of cold feed, open vent and overflow pipes.

BOILER MODEL	COLD FEED		OPEN VENT		OVERFLOW	
HT46R	3/4"	22mm	1"	28mm	1"	28mm
HT50R	1"	28mm	1 1/4"	35mm	1"	28mm
HT60R	1"	28mm	1 1/4"	35mm	1"	28mm
HT70R	1"	28mm	1 1/4"	35mm	1"	28mm
HT80R	1 1/2"	40mm	2"	50mm	2"	50mm

- The feed and expansion tank should be capable of withstanding boiling water and preferably be of galvanised iron with sufficient capacity to allow the water in the system to expand by 3.5% **without** overflowing. We therefore recommend the feed and expansion tank capacity should be 6% of total water in system.
- The float valve should be fitted with a copper float to withstand the effects of overheating.
- Overflow pipe from the feed and expansion tank **must** be copper or iron.
- A safety valve must be fitted to suit the static head of water (refer BS759). The minimum discharge aperture should be 1 1/2", and should be directed away from any passer-by. (Teisen Products can supply)
- A pumped shunt system should be included to prevent back-end corrosion, improve combustion and overall efficiency. For systems without accumulators, a small domestic circulating pump can be used, controlled by a thermostat installed on the main return pipe. The thermostat should be wired to maintain the return temperature above 57°C.

For systems with an accumulator the shunt is controlled via the flow temperature using a clamp-on pipe thermostat wired to make on a rise in temperature (60°C).

- The thermostats and temperature gauge must be positioned in the boiler jacket, primary flow or shunt circuit if it is a fully pumped system. **Do not fit them in a "blind" pipe.**

G. ACCUMULATOR SYSTEMS

All HTR Boilers must be fitted with accumulator.

Accumulator system has the following advantages:-

- Enables low stoking frequency (typically once/twice per day)
- Enables boiler to operate at higher combustion efficiency, due to un-interrupted burn
- Allows increased flexibility of stoking times with improved convenience i.e. you can stoke when you want to, rather than when you have to.
- Stores heat ahead of requirement (e.g. grain drying, greenhouse, piggery night time heating etc)
- Acts as heat leak.
- Ensures clean combustion with lower maintenance and cleaning requirement.
- Prolongs boiler life

PUMP ASSISTED SEMI GRAVITY SYSTEM - See page 12 for details

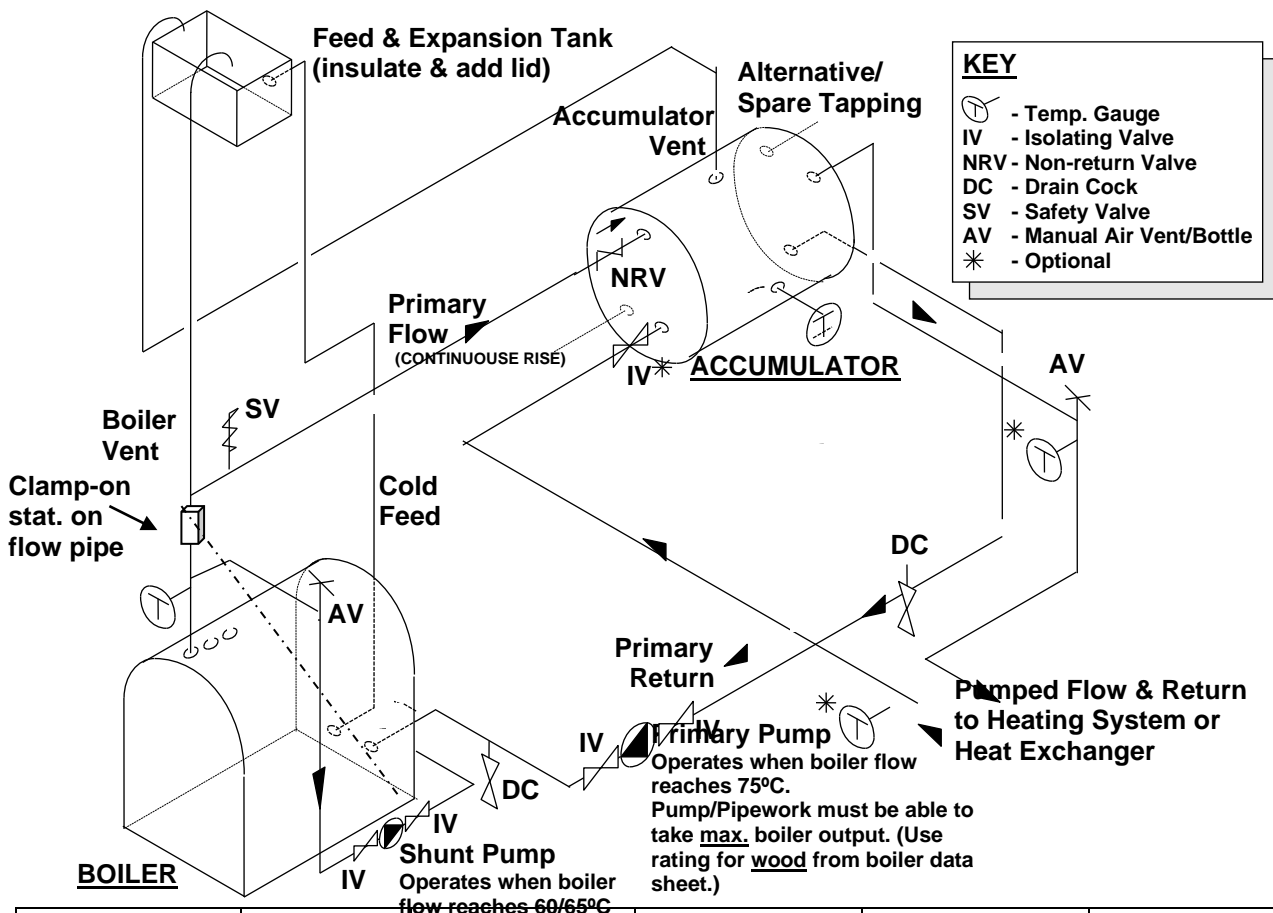

BOILER	HT46R	HT50R	HT60R	HT70R	HT80R
Recommended Pumped Primary Pipe Size (Min.)	1½"	2"	2½"	2½"	3"

Important: See also Typical boiler and accumulator system/remote system (page 12 & 13)

GRAVITY ACCUMULATOR SYSTEM

NOTE
 All Gravity Flow & Return pipework to have minimum 10% rise.
 'Swept' Bends and 'Pitcher' Tees to be used NOT elbows.

KEY
 ⊕ - Temp. Gauge
 IV - Isolating Valve
 DC - Drain Cock
 SV - Safety Valve
 AV - Manual Air Vent/Bottle
 * - Optional

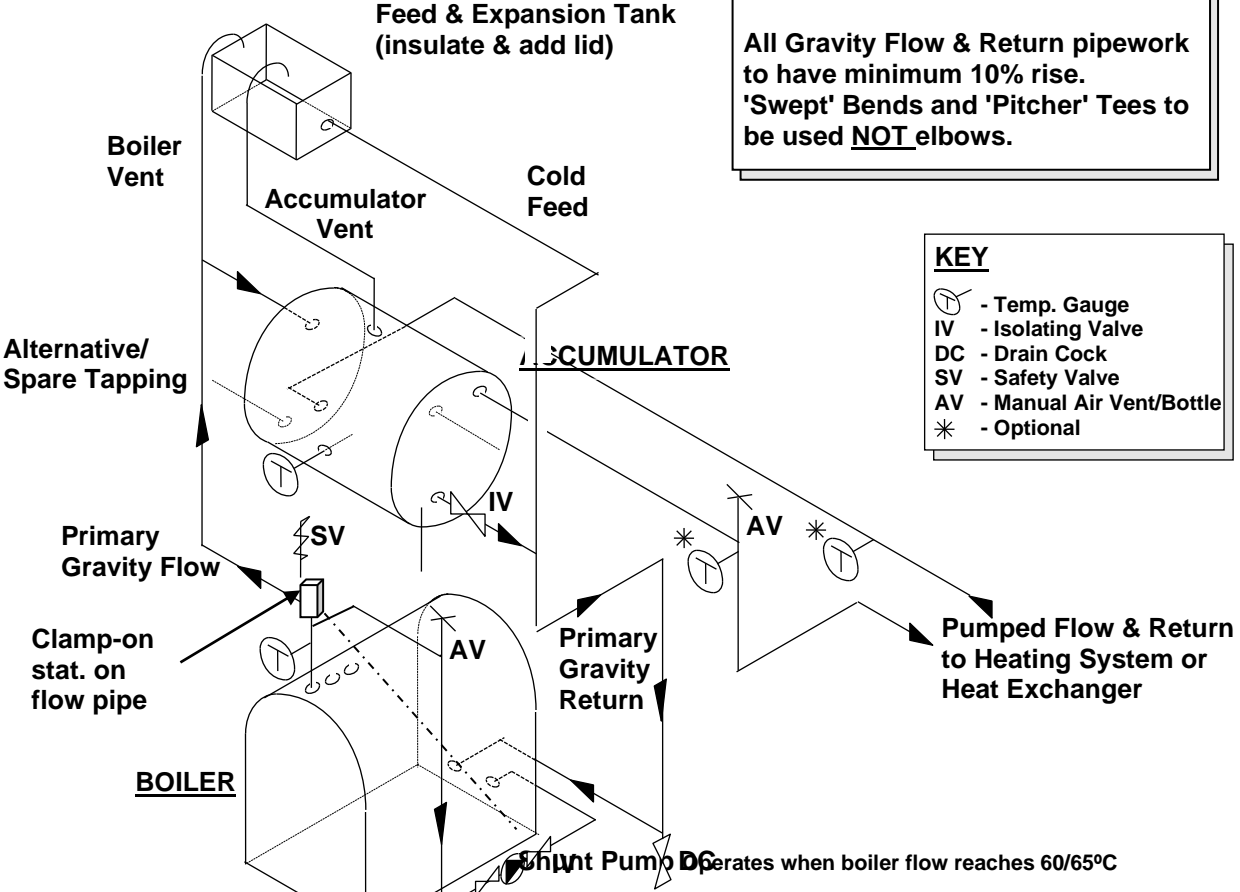

BOILER	HT46R	HT50R	HT60R	HT70R	HT80R
Recommended Gravity Primary Pipe Size (Min.)	3"	4"	4"	5"	5"

General Notes:

- Galvanised F. & E. tank capacity at least 6% of total water content. Cold fill to at least 50mm depth.
- Open vent at highest point. Boiler and accumulator **must have** continuously rising open vent.
- Heat demand outlet to be at **opposite end** of tank from primary flow from boiler, and from opposite end of demand return. Return to boiler to be at **opposite end** of tank from primary flow.
- Accumulator to have minimum 100mm glass wool insulation or equivalent spray foam on all surfaces.
- Recommended water capacity **as big as possible**, ideally at least 80litres/kW output. Sufficient to absorb at least half the energy value of the fuel in the boiler (1000 gallons/4500 litres stores 450,000 BTU's or 135 kWhs) e.g. HT50R. Minimum water capacity 2500 litres, HT70 12800 litres.
The above are min. capacities. For maximum efficiency and convenience, we recommend at least 50% larger.
- Accumulator must be raised fully above boiler if gravity circulation only is required (i.e. no pump).*
- Boiler control should be set to approximately 85°C. Primary pump should be set as high as possible without the boiler overheating (i.e. 75 °C or above)
 * For pump assisted gravity system, i.e. accumulator on ground next to boiler, top of accumulator should preferably be at least 60cm above top of boiler, the higher the better.

Important: See also Typical boiler and accumulator system/remote system (page 12 & 13)

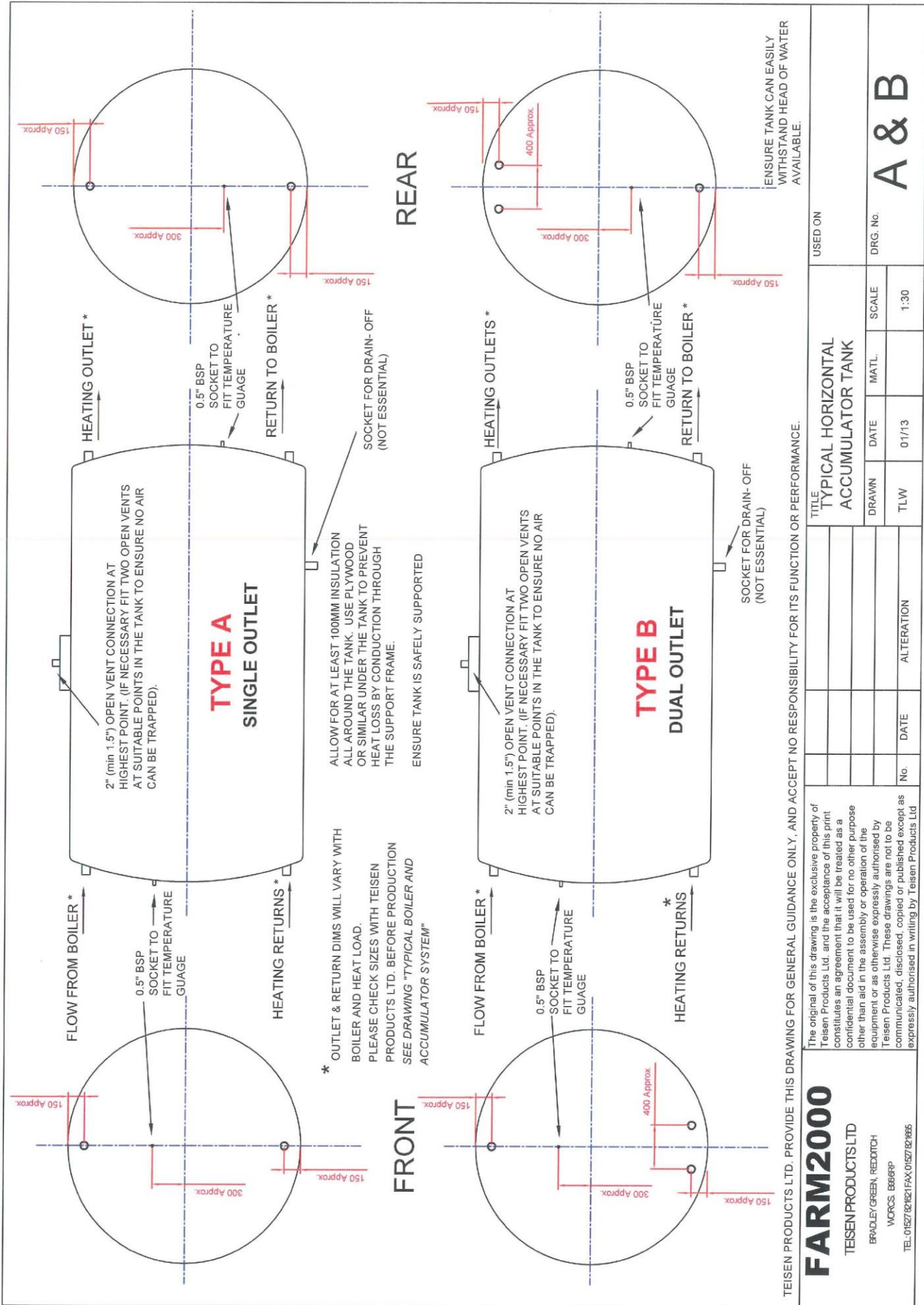

See over/next for Remote System

Recommended Pumped Primary Pipe Size (min.)			
HT46R, HT50R	HT60R, HT70R	HT80R	BB144/3R BB146/3R BB154/R3
2"	2 1/2"	3"	3"
			BB244/3R BB254/3R BB254H/3R
			4"

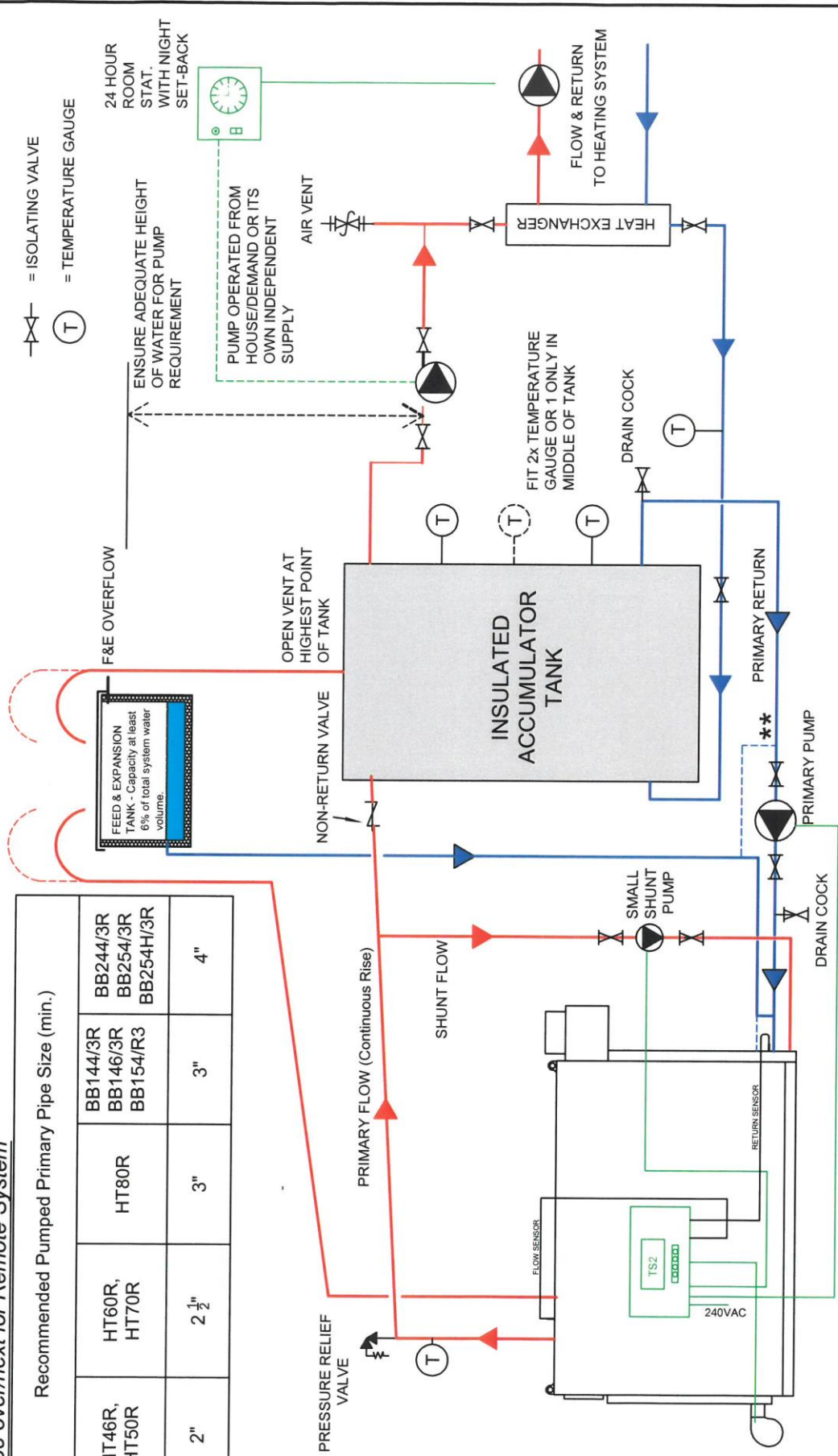

** Depending on height available at F & E tank, cold feed may alternatively be connected into pump return

Tank Size Guide: 1000 gallons stores 450,000 BTU approx.
4500 litres stores 135 kWhrs approx.

FARM2000
M&K Products (Bromsgrove) Ltd
Dodford, Bromsgrove, Worcs. B61 9BT
Tel: 01527 836444 e-mail: heat@farm2000.co.uk

These details are given for guidance only and represent a typical system layout.
M&K Products (Bromsgrove) Ltd/FARM2000 can not take responsibility for boiler installations. Customers should consult their heating engineer to confirm final layout, pipe/pump size etc.

DRAWING TITLE
Typical Boiler and Accumulator System

DRAWN	DATE	MATL.	SCALE	DRG No.
TLW	06/16			

USED ON

See over/next for more detail

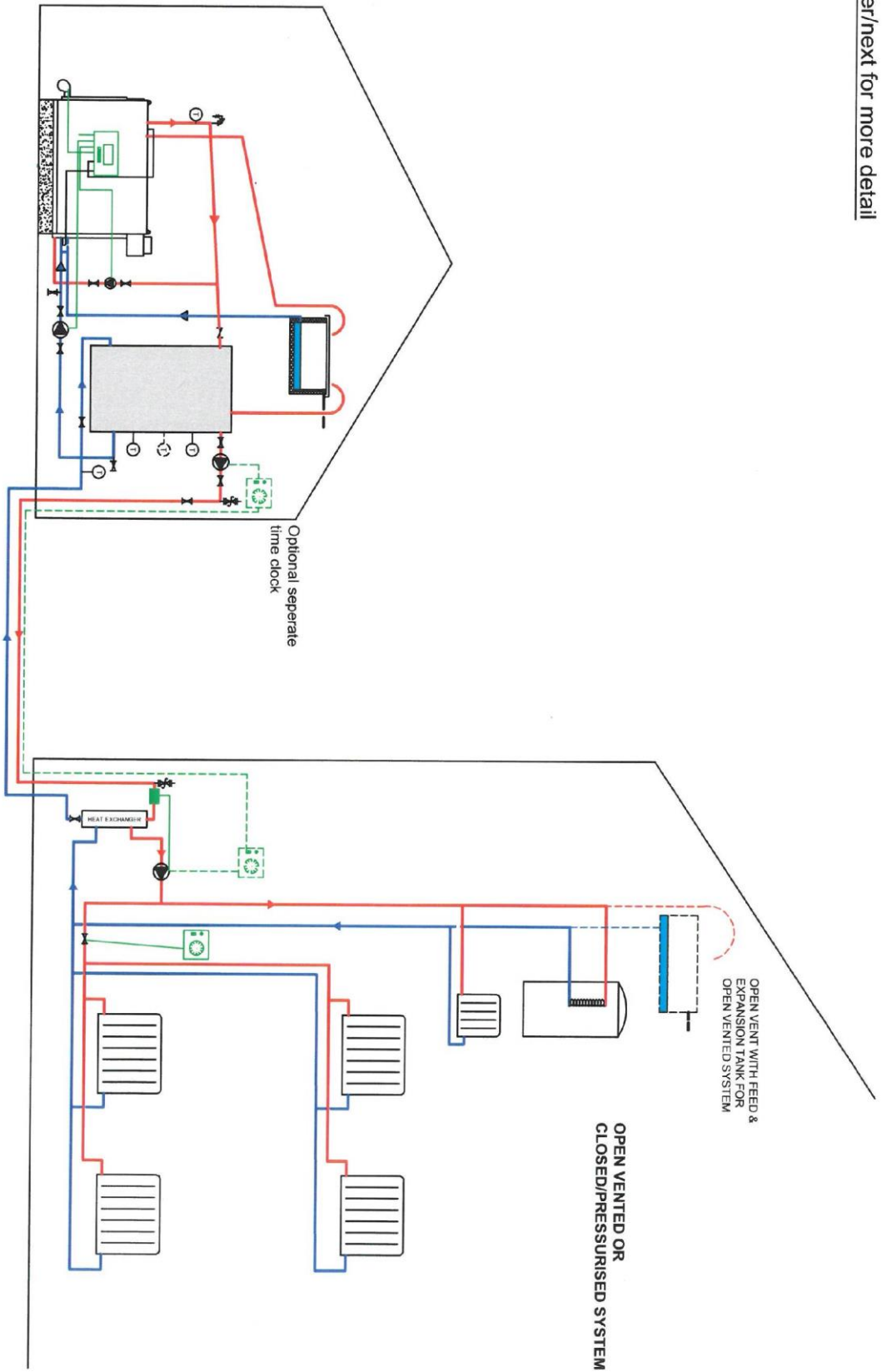

FARM2000
 M&K Products (Bromsgrove) Ltd
 Dodford, Bromsgrove, Worcs. B61 9BT
 Tel: 01527 836444 e-mail: heat@farm2000.co.uk

These details are given for guidance only and represent a typical system layout.
 M&K Products (Bromsgrove) Ltd/FARM2000 can not take responsibility for boiler installations. Customers should consult their heating engineer to confirm final layout, pipe/pump size etc.

No.	DATE	ALTERATION

DRAWING TITLE
**Typical Boiler and
 REMOTE Accumulator
 System**

DRAWN	DATE	MATL.	SCALE
TLW	01/13		

USED ON

DRG No.

H. FAN CONTROL UNITS

1. **FARM2000 TS3 CONTROL** – used on boiler models HT46R, HT60R, HT70R, HT80R, BB144/3R, BB146/3R, BB154/3R, BB244/3R from October 2016

Control overview

The TS3 control monitors the boiler’s water temperature and running time to control the **combustion fan, primary circulation pump and shunt pump** at different times throughout the combustion cycle.

When burning straw the TS3 control also operates the motorised primary/secondary air damper.

The system comprises a colour display with touch screen user input plus connector interface for temperature sensors, pumps and combustion fan, etc.

It is strongly recommended that all electrical components (e.g. pumps, thermostats, control box etc.) are wired from the same source of supply.

TS3 Layout of user interface

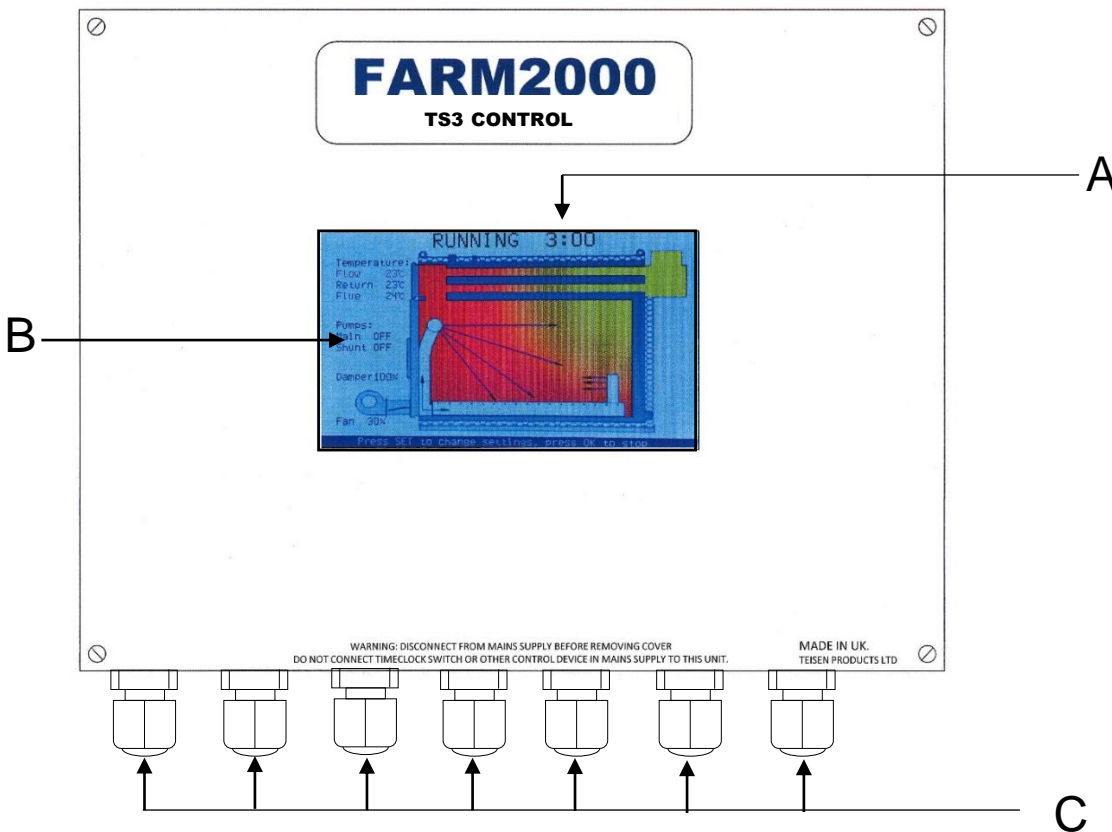

Part	Function
A	<ul style="list-style-type: none"> displays boiler status displays SETUP menu displays parameters and their ranges displays comment/instruction with each parameter
B	<ul style="list-style-type: none"> touch screen <ul style="list-style-type: none"> press the boiler image to bring up the settings menu
C	<ul style="list-style-type: none"> cable entry to control box for sensors, pumps and fan, etc

TS3 Electrical Supply

Supply Voltage: 230V/50Hz AC single phase supply
Supply current: 6 amps max.
Board Fuses: 6 amp, 20mm F type fuse - outputs
1.25 amp, 20mm F type fuse - control board power supply.

2. FARM2000 TS3E CONTROL – used on boiler models BB254/3R and BB254H/3R from October 2016

Control overview

The TS3E control utilises an AC drive mounted in the control cabinet to convert a 32 amp, 230V/50Hz single phase input to a 230V/50Hz three phase output to drive the boiler fan.

The TS3E control monitors the boiler's water temperature and running time to control the **combustion fan, primary circulation pump and shunt pump** at different times throughout the combustion cycle.

When burning straw the TS3E control also operates the motorised primary/secondary air damper.

The system comprises a colour display with 4 button user input plus connector interface for temperature sensors, pumps and combustion fan etc.

It is strongly recommended that all electrical components (e.g. pumps, thermostats, control box, etc.) are wired from the same source of supply.

The control display, variables and their setting are identical in both TS3 and TS3E variants of the boiler control. This manual then refers to both the TS3 & TS3E variant unless any specific differences exist.

TS3E Layout of user interface

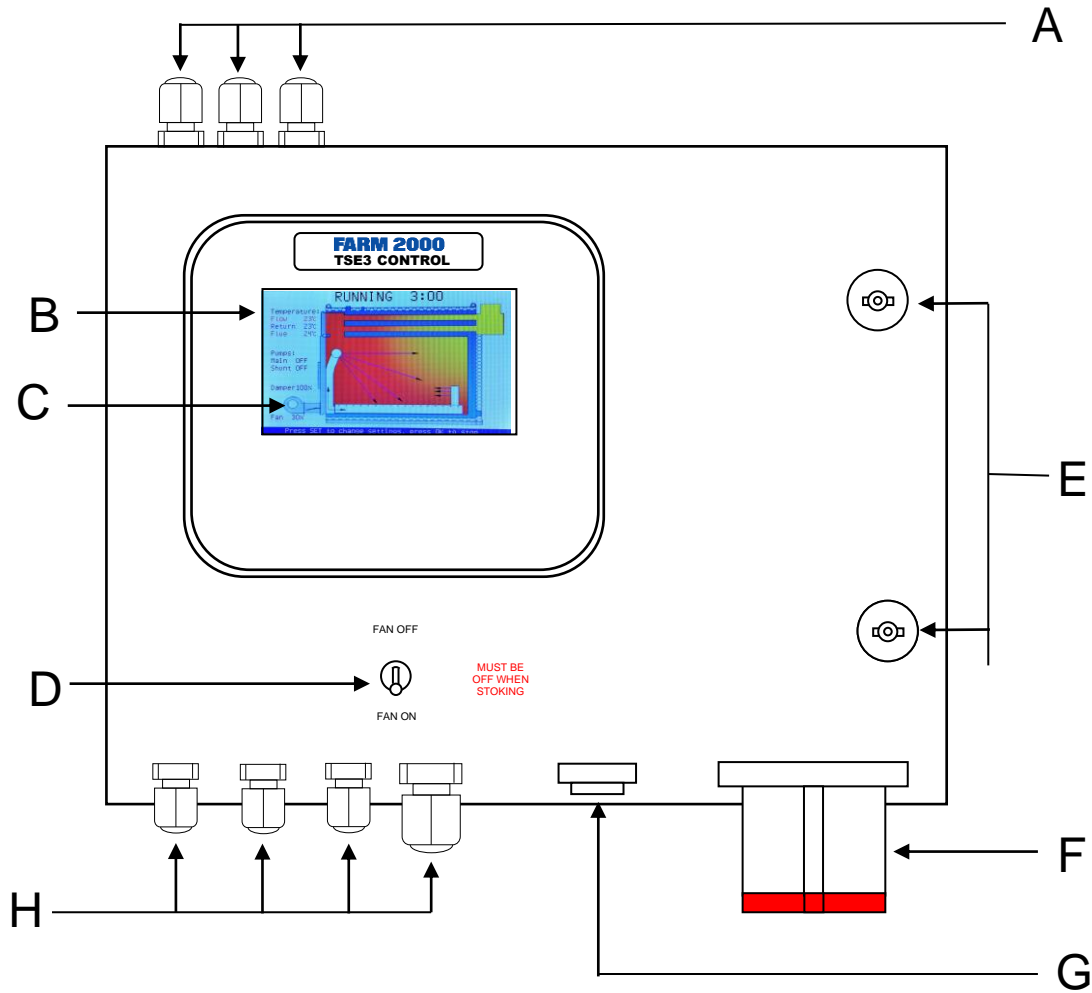

	Part	Function
A	Cable glands	<ul style="list-style-type: none"> • Flow Water Temperature Sensor • Return Water Temperature Sensor • Flue Gas Temperature Sensor (Optional)
B	Display	<ul style="list-style-type: none"> • displays boiler status • displays SETUP menu • displays parameters and their ranges • displays comment/instruction with each parameter
C	User Input	<ul style="list-style-type: none"> • touch screen <ul style="list-style-type: none"> ○ press the boiler image to bring up the settings menu
D	Fan on/off	<ul style="list-style-type: none"> • Manual fan on/off switch
E	Cabinet Locks	<ul style="list-style-type: none"> • For access to control cabinet fuses etc.
F	Motor Connector	<ul style="list-style-type: none"> • 32 amp 230V/50Hz 3 phase motor connector
G	Damper Connector	<ul style="list-style-type: none"> • 3 pin 230V/50Hz single phase connector
H	Cable glands	<ul style="list-style-type: none"> • cable entry to control box for 32 amp mains supply, primary pump, shunt pump and optional chimney fan control

TS3E Electrical Supply

Supply Voltage: 230VAC/50Hz single phase supply
Supply current: 32 amps max.
Board Fuses: 6 amp, 20mm F type fuse - outputs
1.25 amp, 20mm F type fuse - control board power supply.
Control Fuses: 20 amp MCB - supply input
6 amp MCB – primary pump

Control screen options.

Display layout – Boiler operating

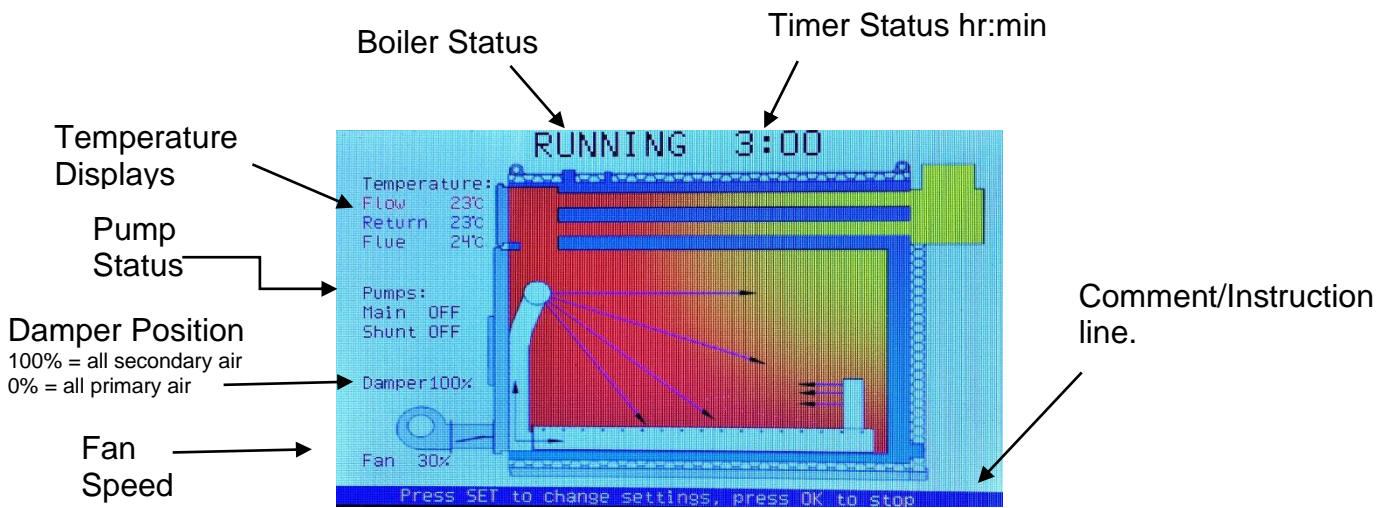

Display layout - Setup

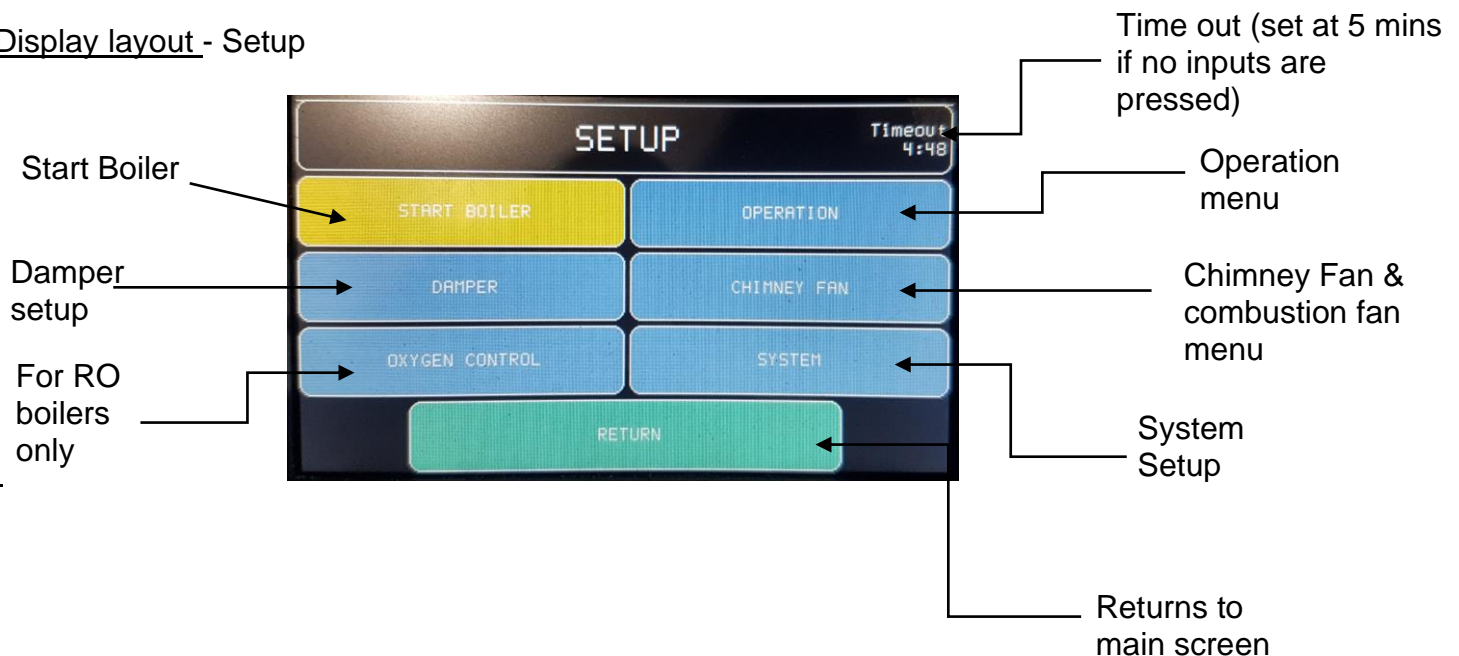

Display layout – Modify selected parameter.

Select a menu page from the SETUP menu. In this example OPERATION menu has been selected.

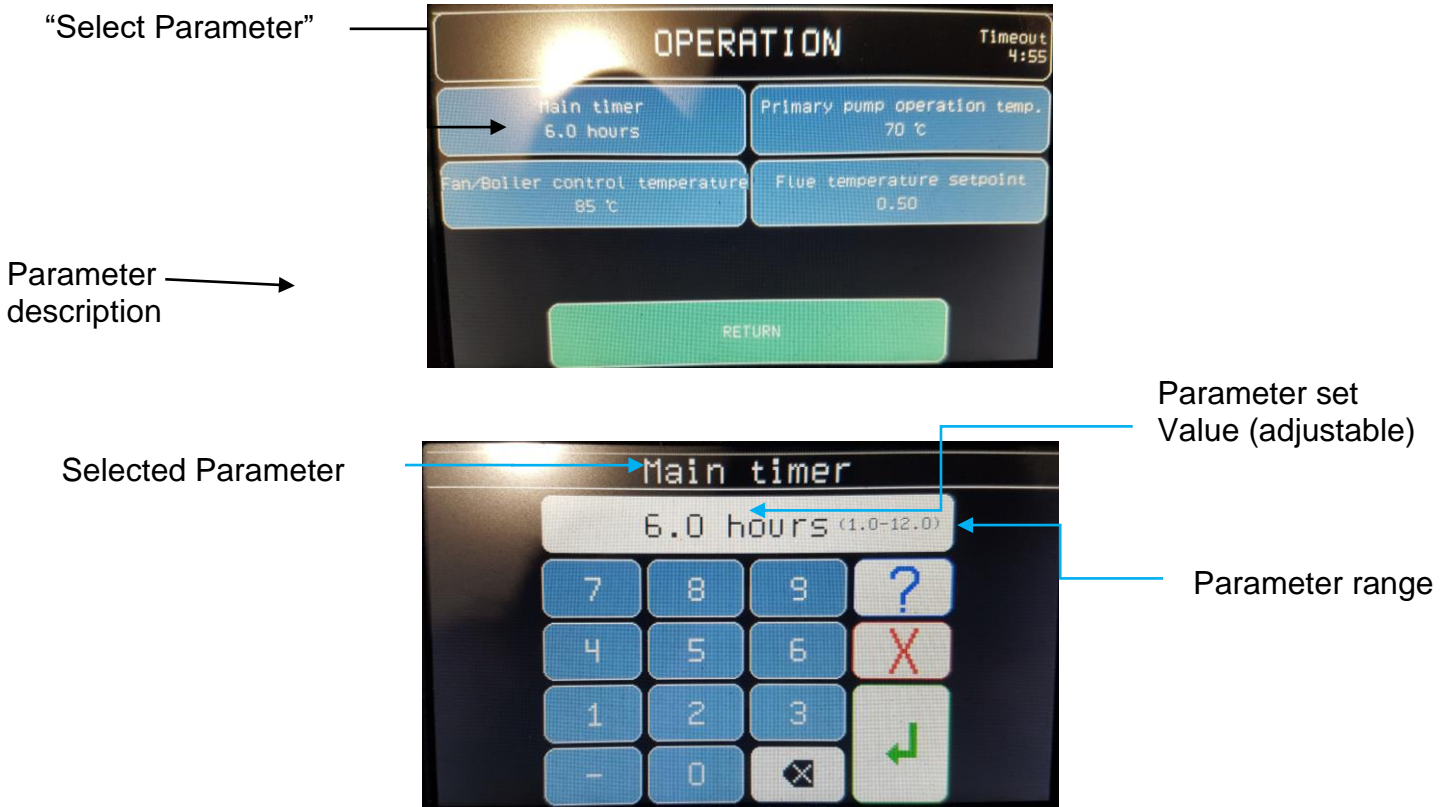

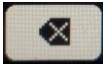
To alter the press the  button to clear the current value.

Then enter the new value with the number keypad.

Then press the  button to enter your new value.

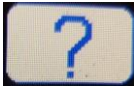
To ensure you are altering the correct parameter press the  button for more information about the parameter. A screen appears as below.

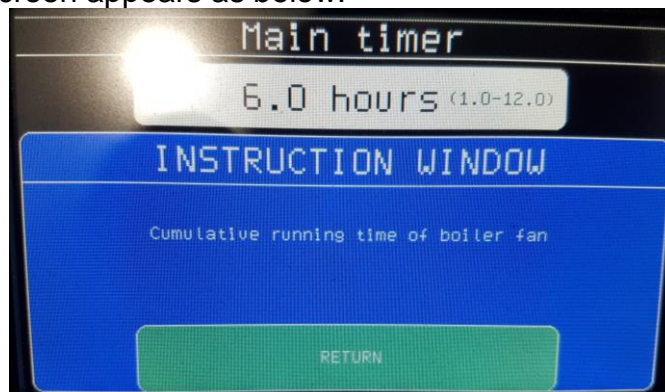

All boilers are also fitted with a manual fan on/off switch used to turn the boiler fan on/off when the stoker door is opened etc. Dependant on boiler model this is located in the control unit or on the boiler fan itself.

Mounting TS3 & TS3E Control Units

The TS3 control is generally mounted on the side of the boiler on the same side as the boiler door hinges, using the 4x No8 self-drilling screws supplied,

the TS3E control cabinet is mounted with 4x No8 self-drilling screws.

The control unit should be located a minimum of 300mm back from the boiler front plate, on the “flat” section of the boiler casing/cladding.

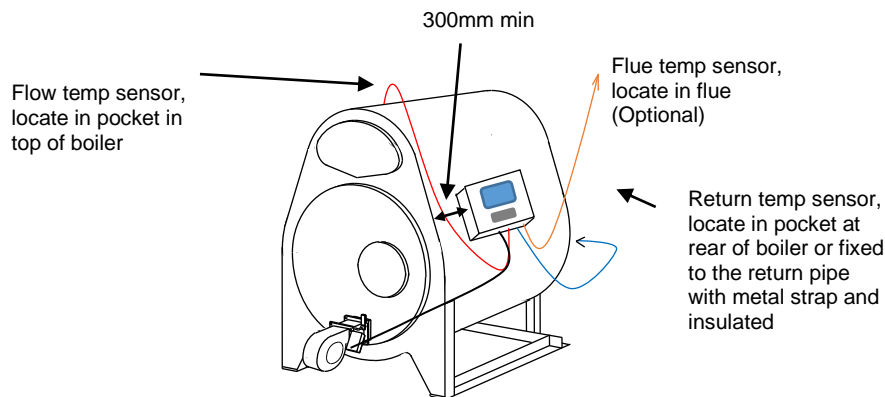

Fit the FLOW temperature sensor in the brass pocket located in the top of the boiler, making sure the sensor is pushed to the bottom of the pocket and held in place by spring clip supplied.

Fit the RETURN temperature sensor in the brass pocket in the back of the boiler, making sure the sensor is pushed to the bottom of the pocket and held in place by spring clip supplied; or fix to the return water pipe immediately behind the boiler using metal cable ties etc, before fully insulating.

The optional Flue temperature sensor can be fitted in the boiler chimney. To fit this sensor drill a 6mm diameter hole through both inner and outer walls of the chimney approx. 500mm to 1000mm above the flue spigot.

Insert the flue sensor into the chimney until the end of the steel sensor body is flush with the outer surface of the chimney.

Alternatively, the control unit may be mounted on a suitable wall or stand but care must be taken that the fan loom and/or sensor cables are of sufficient length to reach the intended mounting position.

The control and fan must be fully protected from water ingress, exposure to direct rain, etc. which will damage the control system.

The control must be installed by a qualified electrician in accordance with all current electrical rules and legislation.

All cables must pass through the cable grommets provided in the control enclosure.

Connect TS3 control to a 230VAC/50Hz/16amp mains supply and the TS3E to a 230VAC/50Hz/32 amp mains supply via a double pole switched fuse.

This supply **must not** be connected through a time clock switch or other control device.

When accessing control box/cabinet care should be taken not to disturb 2x ribbon cables connecting display, etc. to control board.

OPERATION

Start Sequence – at power up.

If the control is being connected to the mains supply for the first time or the mains supply has been interrupted at any time, the start sequence will differ slightly from normal operation as follows,

- Turn mains supply on at main isolator
- Display will show “WAIT” for approx. 15 secs while system reads sensors.
- If sensors are within range AND the actual boiler temperature is 10°C below the SET boiler temperature the display will show READY
- Touch the screen to enter the SETUP screen and then press START BOILER to start the combustion cycle, display will then show RUNNING.
- The display will show the set timer period as a countdown function.

Note: when the mains supply is first connected to TS3E system the fan will start to rotate immediately at slow speed, if the boiler is left in the READY mode the fan will fully stop after a short time.

Similarly when the boiler shows FINISHED, or STOP BOILER is pressed to interrupt a cycle, the fan may take several minutes before coming to a complete stop.

Control parameter SETUP

The user may access the control SETUP menu at any time while the control is powered, and in general use. Parameters would generally, if required, be adjusted before a combustion cycle is started.

The user can however modify the SETUP parameters while the boiler is operating, i.e. fan speed, pump operating temperature etc. The boiler will continue to operate as normal as any changes are made.

When the boiler is running any, changes to fan speed, etc. take immediate effect, i.e. fan speed will increase with each increment made on screen.

Note, if the “Manual operation of outputs” function is selected, all boiler operating functions will be inhibited.

To enter the SETUP menu  MAIN SCREEN

To exit SETUP menu  RETURN

The following parameters are available to the user.

Press the main screen to enter the SETUP MENU (as below)



From the SETUP MENU you can select the following sub menus:

OPERATION

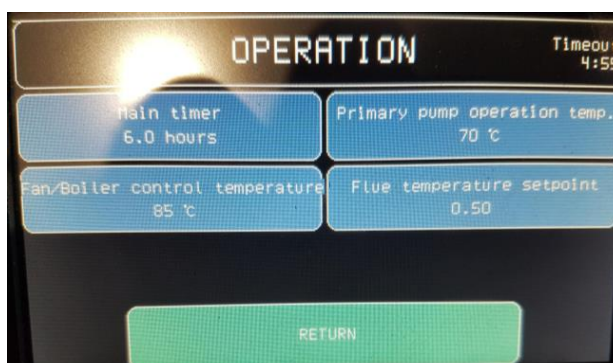

- Main Timer (1-12 hours)

This limits the total **accumulated running** time of the fan, and should be set to suit the type and quantity of fuel loaded. The operating range is 1 to 12 hours and as an approximate guide it should be set as **low** as possible to prevent cooling of the boiler whilst ensuring all of the fuel is completely burnt out. Depending on the fuel being used, the boiler will continue to produce output for some time after the fan has stopped.

- Primary pump operating temperature (15 - 100°C)

This sets the operating temperature for the primary circulation pump,

- a) when used to operate circulating pump from accumulator, set at approx. 75°C
- b) when boiler used without accumulator, can be set at 60°C to operate central heating pump, or set at 90°C to operate as a heat dump if separate pump control fitted in house (i.e. programmer or thermostat etc.)

If set too low, the pump will continue circulating after the boiler has cooled down, thereby cooling the accumulator

Note: this output should be used to drive the primary pump indirectly via suitable control relay / contactor. Consult your electrician or FARM2000 for further information.

- Fan/Boiler control temperature (15 - 100°C)

Controls the fan to maintain the temperature of the water in the boiler - this must normally be set at approximately 82°C (not less than 80°C), and approximately 85°C with an accumulator system.

- Flue temperature set point (please leave set at 0.50)

CHIMNEY FAN

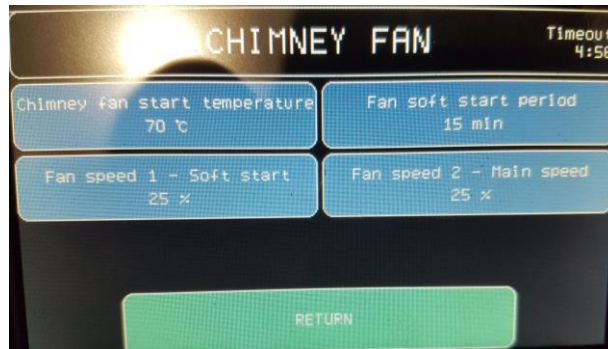

- Chimney fan start temperature (0 - 995 °C)

Provides on/off signal with respect to flue temperature if a chimney fan is fitted. Please contact Farm2000 for further details.

- Fan Soft Start Period (0 -15 mins)

Sets time for which Speed 1 (soft start) operates. Should be set long enough to allow fire to fully establish without being “blown out” by the fan. See installation and operating manual for recommended settings.

If no soft start function required, set period to 0

- Fan speed 1 - soft start (0 - 100%)

Sets speed of fan during soft start period. See installation and operating manual for recommended settings.

- Fan speed 2 - main speed (0 - 100%)

Sets main fan speed. See installation and operating manual for recommended settings.

DAMPER



- Damper active (Y/N)

Turns damper control output on/off. Should be set to ON when burning straw.

When burning wood, damper should be turned OFF and manually set to ‘wood only’ on the damper scale

- Damper start delay (0 - 180mins) Sets delay period from the start of the combustion cycle before damper starts to operate. See installation and operating manual for recommended settings.

- Damper ON time (0 – 15 secs)

Sets damper motor ON time. See installation and operating manual for recommended settings.

- Damper OFF time (0 – 15 mins)

Sets damper motor OFF time. See installation and operating manual for recommended settings.

SYSTEM

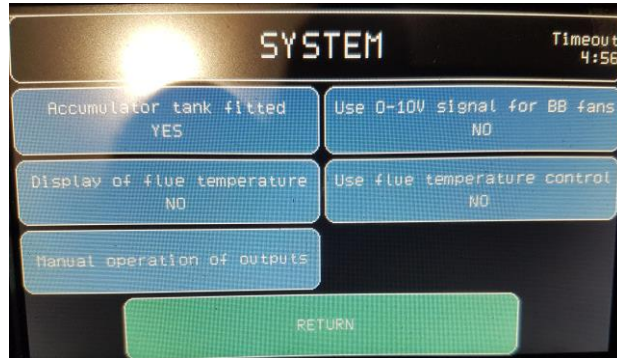

- Accumulator tank fitted (Y/N)

Controls operation of shunt pump.

With accumulator fitted (Y) shunt pump turns on when flow temperature reaches 60°C and turns off when flow temperature is 60°C or above, AND return temperature reaches 75°C

With NO accumulator fitted (N) the shunt pump turns off when return temperature reaches 60°C.

- Use 0-10V Signal to drive fan (Y/N)

Selects control input for boiler fans that are designed to be speed controlled using a 0-10V input.

This parameter will be factory set before boiler despatch, please consult FARM2000 before changing.

- Display of flue temperature value (Y/N)

Turns on/off flue temperature display, default setting is NO

- Use flue temperature control (Y/N)

Turns on flue temperature control, default setting is NO.

- Manual operation of outputs

This function can be used to test the function of all outputs, note that when this parameter is selected, all boiler functions will be inhibited, the fan etc will stop until selected for test, as soon as the user returns to the SETUP menu the boiler will return to normal operation.

*To avoid potentially hazardous operation **DO NOT** use the “manual operation of outputs” function during boiler firing.*

Fan ON/OFF switch.

All boilers are fitted with a FAN ON/OFF switch that allows the operator to manually turn the fan off, this switch is either mounted on the fan or alternatively on the TS3 control box/cabinet dependant on boiler model.

When the fan is manually stopped via the FAN ON/OFF switch the Control will display “**WARNING: FAN OFF**”

Switch should be **ON** whenever boiler is operating and **must** be switched **OFF** when **main door** is opened.

However, fan must remain **ON** if the **small stoker door** is re-opened after light-up (to avoid blow-back).

Start sequence – typical, i.e. next combustion cycle.

- Following completion of the main timer period (shown as a countdown sequence on the display) the display will show FINISHED.
- Pumps will remain operational until set control temperature is achieved.
- 15 seconds after the cycle has finished AND if the actual boiler temperature has fallen 10°C below the boiler SET temperature, the display will show READY.
- If the boiler has not had sufficient time to drop 10°C below the SET boiler temperature, the display will show WAIT.
- The user will not be able to start the next cycle until the display shows READY, i.e. the boiler temperature has fallen 10°C below the SET boiler temperature.
- When the display shows READY  START BOILER to start cycle.

Damper operation sequence

- When START BOILER is pressed to start cycle, damper will start to move to its home (start) position, the display will show DAMPER 100% when the home position has been achieved. (100% = all secondary air, 0% = all primary air)
- Regardless of actual damper start position the controller will operate the damper output for 2.5 mins to ensure damper is moved to the correct starting position.
- Damper will then operate as per set damper sequence.
- Damper may be manually adjusted by depressing the clutch button on the damper housing while rotating the “T” handle on the end of the damper shaft.

Shunt pump operation theory

The shunt pump operates under the following parameters:

Accumulator fitted - Shunt pump turns ON when flow temp reaches 60°C

Shunt pump turns OFF when Flow temp is 60°C and return temperature reaches 75 °C

No accumulator fitted – Shunt pump turns ON when flow/return temperature is below 60°C
Shunt pump turns OFF when return temperature reaches 60°C

Manual Testing of outputs.

Selection of “manual testing of outputs” function will inhibit all boiler functions, boiler will return to normal operation when the user returns to the setup menu.

IMPORTANT - to avoid potentially hazardous operation DO NOT use the “manual operation of outputs” function during initial boiler firing, this will turn off the fan and pumps while selected.*

The fan, pump and damper motor outputs can be tested by selecting “MANUAL OUTPUTS” in SYSTEM sub menu.

- From home screen press MAIN SCREEN to enter SETUP MENU
- From the SETUP MENU press the SYSTEM sub menu

- Press MANUAL OUTPUTS to select the outputs
- All boiler functions will now be inhibited, i.e. fan and pumps will stop.
- Press desired output to switch it on / off.
- Press RETURN three times to return to the home screen

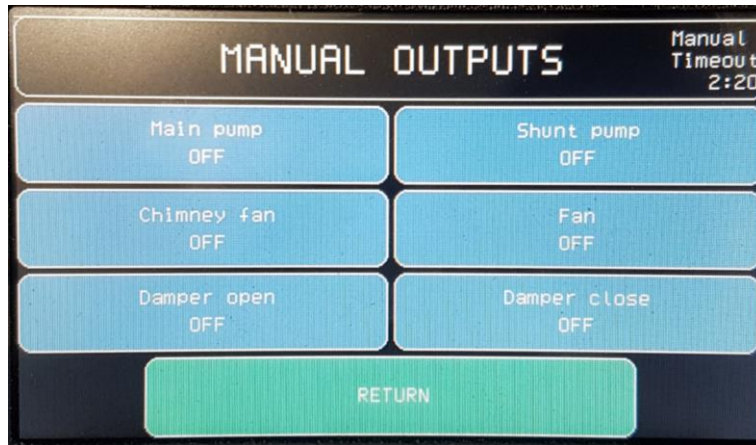

I. ASSEMBLING THE BOILER COMPONENTS

AIR DIVERTER PLATE

Boilers are supplied with the Air Diverter Plate set at the factory. Before assembling other control components to the boiler the position of the air diverter plate should be checked as necessary.

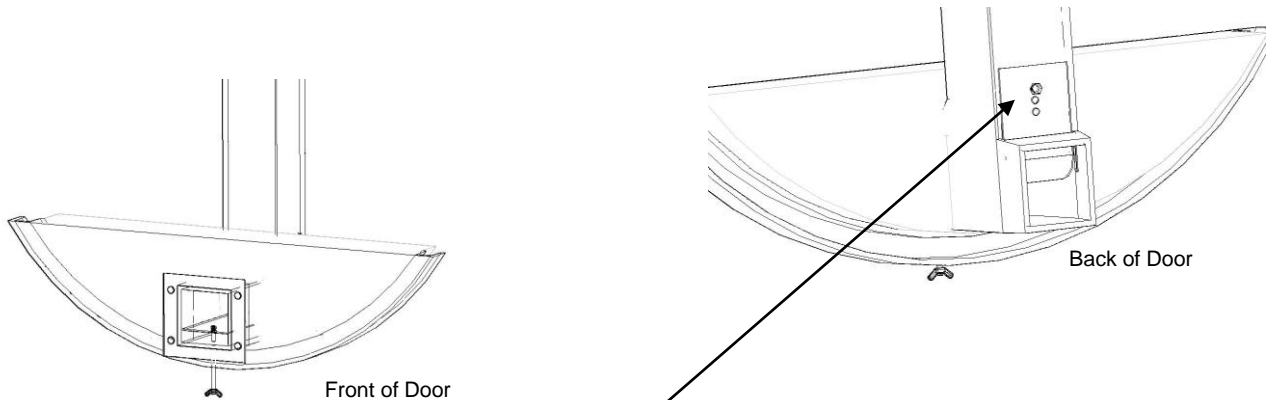

1. Air Diverter Plate fixing screw should be located in the top hole of the diverter plate.
2. The Air Diverter Plate is set as indicated to provide a gap between plate and BOTTOM of the box section.
3. Turning the adjuster screw clockwise increases the primary and rear secondary air.

Air Diverter Plate setting
15 mm for HT50R
20 mm for HT60R, HT70R, HT80R

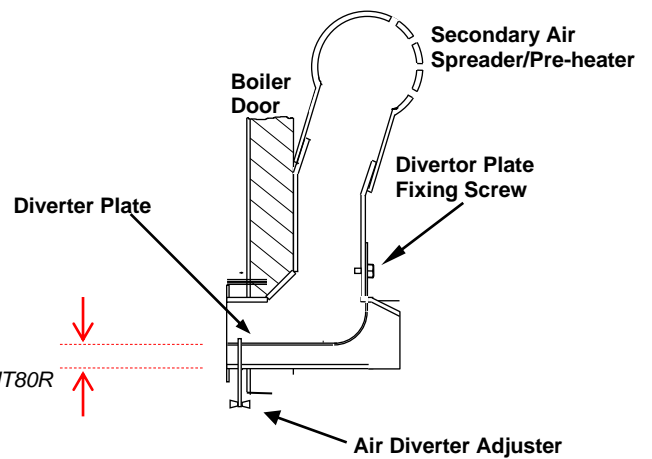

FITTING FAN:

Using the M6 x 16mm screws, nuts and washers provided, attach the fan onto the flange on the door. *Note: a fan mount adaptor is fitted to boiler model HT80R to ensure a smooth air transition between fan and air distribution system.*

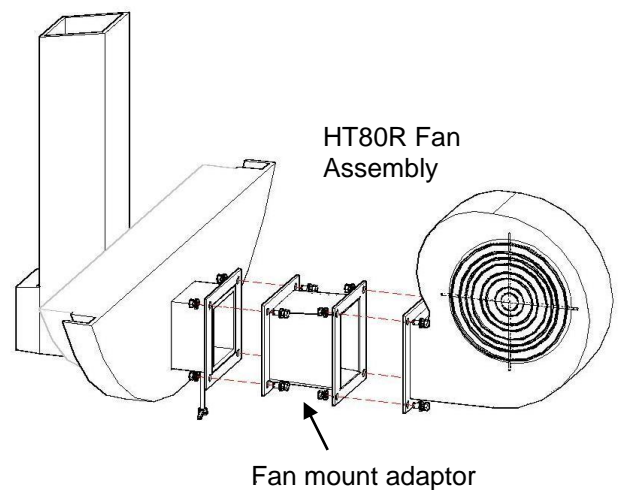
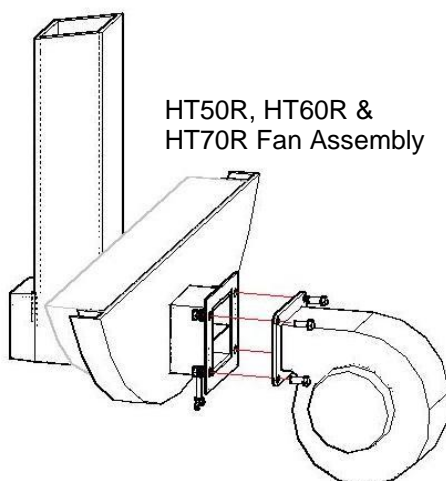

J. COMMISSIONING AND ROUTINE OPERATION OF THE BOILER

IMPORTANT NOTE: Before firing boiler, blow warm air onto the refractory side of the door for 3 – 4 hours. For first “light-up” create small wood fire at back of fire chamber using natural draft for at least 1 – 2 hours, (i.e. small stoker door open), repeat with slightly bigger fire, i.e. do not expose door to intense heat for first light-up.

Boiler should only be fired when accumulator and heat demand can absorb entire fuel charge, i.e. fan operates without interruption. Fuel should only be re-loaded when there is no fire or embers in boiler. However, if the fuel does re-ignite from embers at the back, always ensure that the fire is not smothered by fuel and that flame is well established at the front before starting fan. Failure to do so can lead to a build-up of smoke / un-ignited gases causing pressurisation and blowback.

1. The system must be completely filled with water and all pumps working correctly.
2. Check base duct correctly positioned in chamber (entry gate plate in front of stops), so that air nozzle in door locates into square opening. Check secondary air spreaders are correctly mounted. For boilers with 2-piece base duct, ensure there is no gap between both sections.
3. Set the fan/boiler temperature to approx., 82°C. (When testing the system on the first day, set it to 65°C. When it reaches this temperature and all is well, turn it up to 82°C.) Operating the boiler with fan/boiler temperature set below 75/80°C can potentially cause the boiler to idle for excessive periods resulting in tarring of the boiler and heat exchange tubes and eventual corrosion of the boiler.
4. Set, and leave, the boiler flue damper to fully open.
5. Before lighting the fuel in the boiler, check that sufficient primary and secondary air is available inside the combustion chamber (check through the little stoker door) i.e. feel good airflow with hand.
6. To help flame establishment, set fan at 5 for light-up, and then increase to speed 7 - 8 after 3 - 4 minutes.

Insufficient air (or poor chimney draught) will cause tarring and corrosion. It will also cause oxidation and distortion of the internal metal parts (base duct, air spreaders etc) as they will not be sufficiently air-cooled.

7. Depending on fuel load, set the main timer period to the length of time the fan is required to operate. As a guide, set to 1 hour for every 25 - 50kg of wood. The aim is to ensure the fuel is burned away and the fan has stopped running for at least 2 - 3 hours before re-loading. The boiler will continue to provide a lower heat output for an hour or two after the fan has stopped. The optimum setting is usually found within 2 - 3 days.

Setting the fan time for too long a period will result in blowing cold air into the combustion chamber which will cool the boiler. If set too short it will result in un-burnt fuel being left in the boiler.

8. Having loaded the boiler (see drawing) with fuel, close the main door and start the fire at the front of the combustion chamber, through the small stoker door/flap.

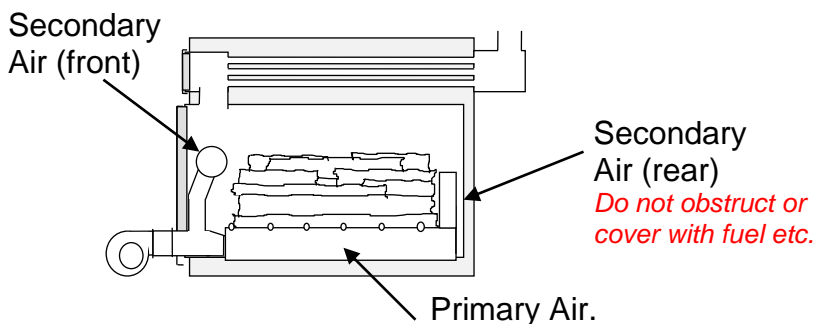

Recommended fuel load approx. 55 kg for HT50R, 100kg for HT60R, 130kg for HT70R and 150kg for HT80R. Load fuel so as to minimise air spaces at base of fuel stack.

Base duct and rear air spreader are consumable items and may need to be replaced periodically.

(Ensure both sections of 2 piece base ducts are correctly joined)

For summer use/periods of low output put less fuel in boiler. Do NOT allow to idle for long periods with boiler full of fuel.

Before starting fan leave small door open for a short time until fire is established, then switch on fan, press timer reset button and then close small door. **It is essential to ensure good flame establishment before starting fan.** This takes longer with wood and with a cold chimney. Keep a check on the water temperature. For fuel that “gasifies” quickly make sure the fire is never starved of air to prevent blowbacks. *If the fuel does not ignite readily, it is an indication of it not being dry enough.*

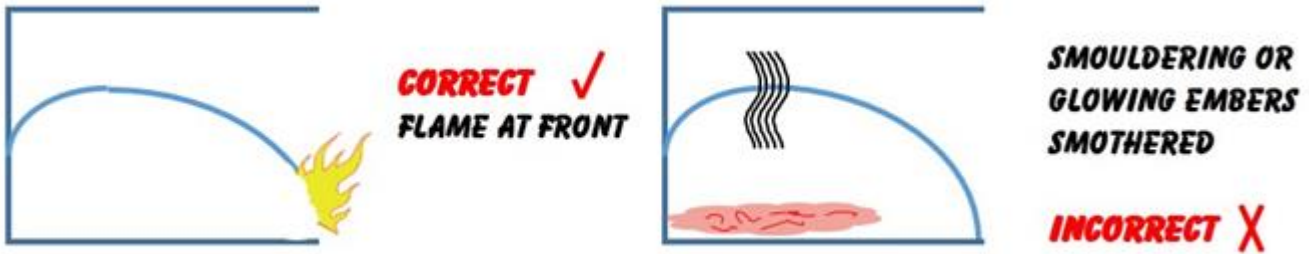

9. When required water temperature is reached, fan switches off and the 'water temperature' neon illuminates. As boiler cools, the fan restarts and fire is re-activated. Boiler should not be fired unless all or at least 75% of the fuel charge can be burned through without interruption. This cycle continues until time period set on the main timer has elapsed. Fan then switches off and 'timer off' neon illuminates. Temperature will gradually fall from 82/83°C to around 60°C, whilst the boiler continues to provide a (lower) output.
10. Flue damper should remain fully open most of the time. It is possible to make fuel savings by throttling the damper down but this should only be done after the fuel has burned for at least 2 hours and must not cause pressurisation of the combustion chamber. The damper must be opened again when boiler is reloaded. **If in doubt leave it open all the time.**
11. **IMPORTANT** When stoking/re-lighting boiler with fuel that quickly re-ignites, whether through main door or small stoker door, it is advisable not to close the small stoker door before starting fan, i.e. open the small stoker door as you close main door, allow fire to establish with good flame formation at the front, start fan, press green button and then quickly close small stoker door.
12. Operation with small stoker door open for more than a few minutes is dangerous and can cause over heating. The appliance must not be operated with the door left open after light up except as directed above.
13. The maximum amount of fuel specified in this manual should not be exceeded. Overloading will cause instability and smoke.

SAFETY NOTE:

- Do not open MAIN DOOR after light-up i.e. while fuel is burning
- Before opening the MAIN DOOR always switch the fan off.
- HOWEVER, the SMALL STOKER DOOR should not be opened after firing unless the fan is running. Failure to do this can result in a sudden ingress of air which can cause blow-back.

K. 24 HOUR THERMOSTATIC CONTROL WITH 5°C NIGHT SET-BACK

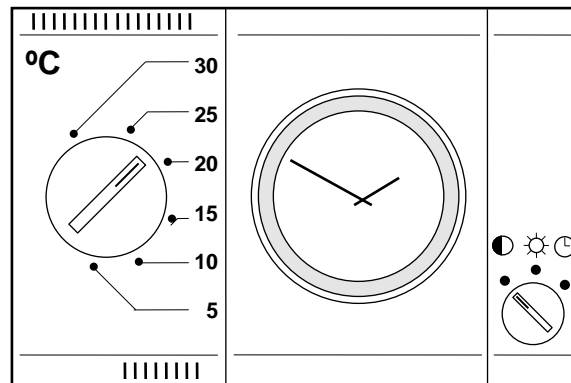

For every 1°C above 20°C that a house is heated, fuel consumption increases by 6%.

It is uneconomical (and uncomfortable) to overheat your house, particularly during the night, a control thermostat with time clock should be fitted in the house to regulate the required temperature by controlling the water circulation.

The ideal temperature control is a room thermostat with 24hr. time clock and night set-back facility. This lowers the pre-set temperature by 5°C (or more) automatically at required times during the day or night. In this way the structure of the house does not cool and a comfortable temperature is quickly re-established when required.

The room thermostat should be wired to the main circulating pump, or if a fully pumped system is used, to a motorised valve (see lay-outs). The boiler will usually feed the domestic hot water and primary system, on a continuous timed system.

L. SAFETY

1. Boiler room must be kept swept clean and free from fuel and combustible material. **A hose and fire extinguisher must be available at all times between the boiler and exit from the boiler room.**
2. **NEVER** leave the boiler unattended when the combustion chamber door or stoker door is open whilst it is alight.
3. Do not allow children into the boiler room.
4. Always take care when opening either the main or stoker door. Stand back and to one side; **do not peer into the combustion chamber.**
5. Ensure that the **fan is operating** when opening the small stoker door. **Do not** open within one hour of stoking the boiler, and **do not** open if there has been a failure in the power supply.
6. **Always** switch the fan off when opening the main boiler door.
7. When the control thermostat switches off the fan, the output of the boiler is reduced to a minimum; this should prevent overheating and the limit thermostat should switch on the main pump if the boiler still produces too much heat. On boilers without a limit thermostat, where overheating occurs, turn on the heating system and/or turn on the hot taps to cool the system. If necessary extinguish the fire using sand, soil or damp gravel - **do not use water.**
8. If water is lost from the system and the boiler while it is still hot **DO NOT TOP IT UP** - this could result in an explosion. Wait until the boiler has cooled down and call in a heating engineer.
9. The boiler is designed to operate at a water temperature of 80/85°C. It can be operated at up to 90°C provided there is adequate circulation.
10. The boiler must be fully drained if left in an exposed frosty condition unlit.
11. When cleaning ash out of the boiler a suitable dust mask should be worn. Dampen down with water if necessary. Take care that hot ash is disposed of safely.

12. Make sure the door is fastened open during stoking, so it cannot swing closed inadvertently.
13. Ensure that the chimney, flue box, heat exchanger tubes and area above the combustion plate are always kept clean. Failure to do this can cause a build up of pressure and possible blow-back when the door or stoker door/flap is opened. In certain circumstances it could even lead to an explosion.

The illustrated safety advice label is fitted on the boiler. If it has been removed or is illegible or damaged, then contact **Teisen Products** for a replacement.

SAFETY NOTICE
(In compliance with European 'Machinery Directive')

This boiler should only be operated by a competent person, familiar with the instruction book.

1. DO NOT leave boiler doors open if boiler is firing. This can cause a fire hazard.
2. Care should be taken when opening the boiler doors. Always open slowly.
3. DO NOT open small stoker door unless fan is operating. However, switch fan OFF when opening main door.
4. DO NOT open small stoker door in the event of power failure.
5. Beware of possible blow-back when opening small stoker door. DO NOT stand in front of stoker door when opening; stand back and to hinge side.
6. DO NOT peer closely into boiler.
7. Always close doors securely.
8. DO NOT STORE COMBUSTIBLE MATERIAL IN BOILER HOUSE.
9. Heat exchanger tubes, flue box and chimney must be kept clean.
10. Ensure flue damper is fully open when opening boiler doors.

Vertical Flue Spigot

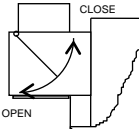

Horizontal Flue Spigot

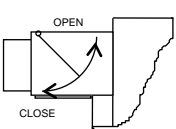

CAUTION: Flue box can become very hot. Combustible material and electrical wiring must be at least 500 mm. from flue box.

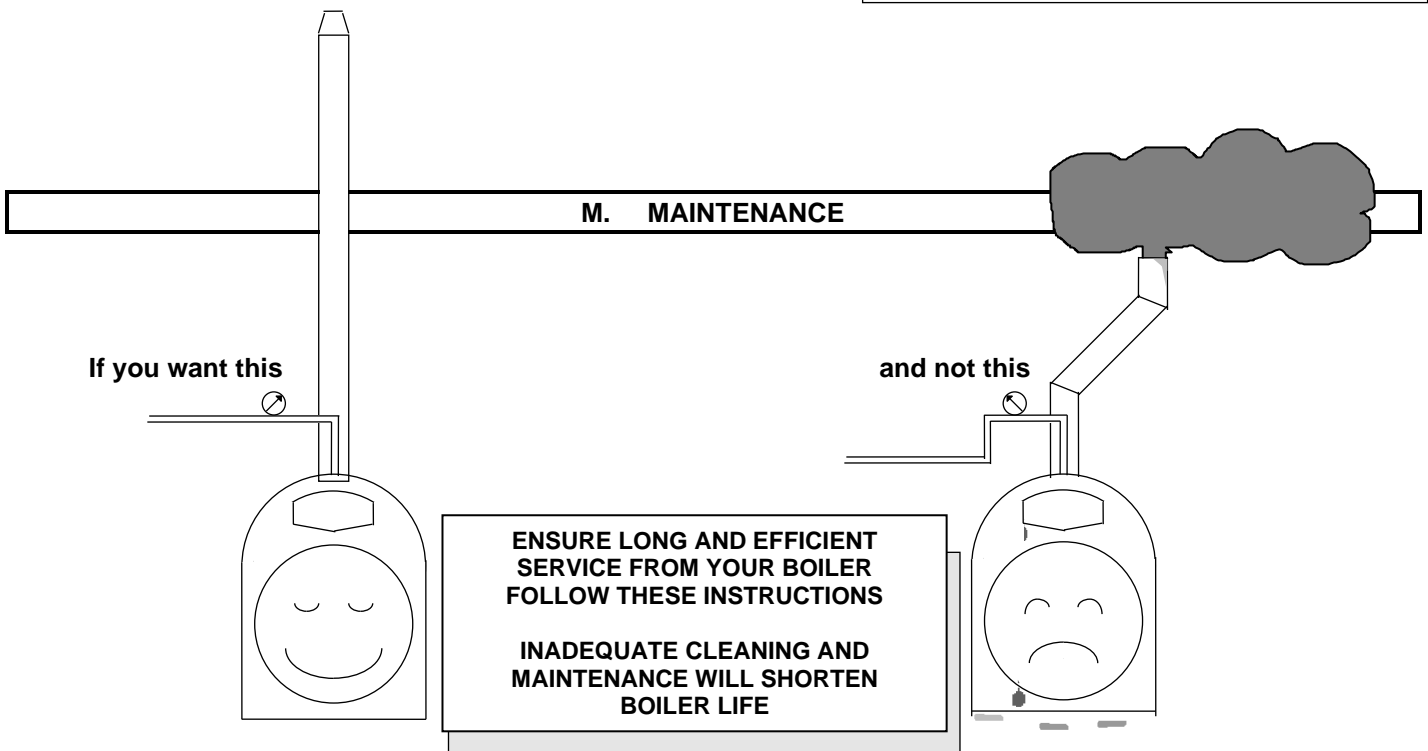

Combustion Chamber

Ash should be removed regularly from the combustion chamber. Ash builds up at a decreasing rate when using wood every 2-3 weeks is usually sufficient. A thin layer of **dry** ash can be left to improve combustion efficiency. When clearing the ash, check that there is no ash in the base and air ducts and that all holes are clear. Clean any deposits from combustion chamber walls. Dampen any hot ash before removing it.

In summer if the boiler is left un-used always clean out all ash deposits and make sure the boiler is ventilated. **When the boiler is operating, the temperature of the water jacket should always be kept above 60°C. The control thermostat should be set at 80/82°C or above. This will ensure minimal deposits within the combustion chamber and heat exchanger tubes. If the boiler operates at temperatures below this, condensation occurs leading to reduced efficiency, increased cleaning frequency and possible problems with boiler corrosion. The hotter the water temperature, the cleaner the boiler!**

Heat Exchanger Tubes

Inspect and clean the heat exchanger tubes regularly; the frequency of cleaning will vary from 1-2 weeks depending upon the fuel. Cleaning the tubes is easier if carried out at regular intervals and when the boiler water jacket is at 70°C or above.

Light deposits can be removed by the wire brush. For heavier deposits use the scraper, rotating it 180° to pull the deposits to the front where they will drop into the combustion chamber. When using the scraper, clean in stages working towards the flue box.

Flue Box

The flue box must be inspected and cleaned out regularly at 3 – 4 week intervals, using a vacuum cleaner, brush or thick glove.

Chimney

Chimneys must be inspected and cleaned at minimum twice per year to ensure adequate draught (i.e. suction) is always available. Even a small layer of deposits will restrict gas flow thereby reducing efficiency and causing the boiler to smoke.

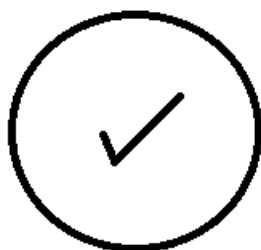

Correct

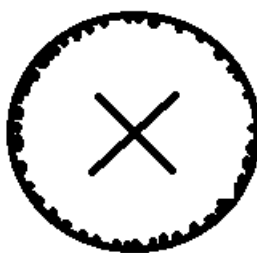

Not acceptable

Pay particular attention to the chimney after prolonged periods at low outputs, i.e. before the winter season begins. If the chimney is allowed to become dirty or partially blocked the resultant decrease in draught will impair combustion efficiency and can, in certain circumstances, cause blow-backs or even a small explosion! It can also lead to corrosion of the boiler.

Use a ***stiff polypropylene*** brush for cleaning stainless steel chimneys (available from **Teisen Products**.) If the chimney and flue box are not kept clean, corrosion can occur.

Fan and Fan Damper

Isolate the fan from the mains and inspect the fan impeller when required. To clean the blades remove the fan guard and carefully brush away deposits with a small brush. If the boiler is operating in a dusty environment the fan should be cleaned more frequently.

Inspect the inside of the fan damper (when fitted) and air ducting at regular intervals; remove any deposits and scrape the sides clean. It is essential that there is always adequate secondary air. Use a counter-sink drill, or wire brush, occasionally to clear the holes on the air spreaders

Boiler out of operation (i.e. summer)

If the boiler is not being used, thoroughly clean out the combustion chamber and heat exchanger tubes and switch off the mains supply to the control unit. Allow the combustion chamber to be ventilated by leaving the stoker door/flap slightly open and the flue damper fully open. If ash is allowed to lie in the boiler for too long, corrosion can occur.

Make sure the boiler is isolated from any source of warm water when not in use.

Seals

Inspect the seals on the flue access plate, manifold cover, main door and small stoker door/flap and check for wear; adjust the door catch if necessary to ensure an airtight seal. Replace every 2 – 3 years. Replacements are available from **Teisen Products Ltd**.

N. CONTROL BOX WIRING DIAGRAM

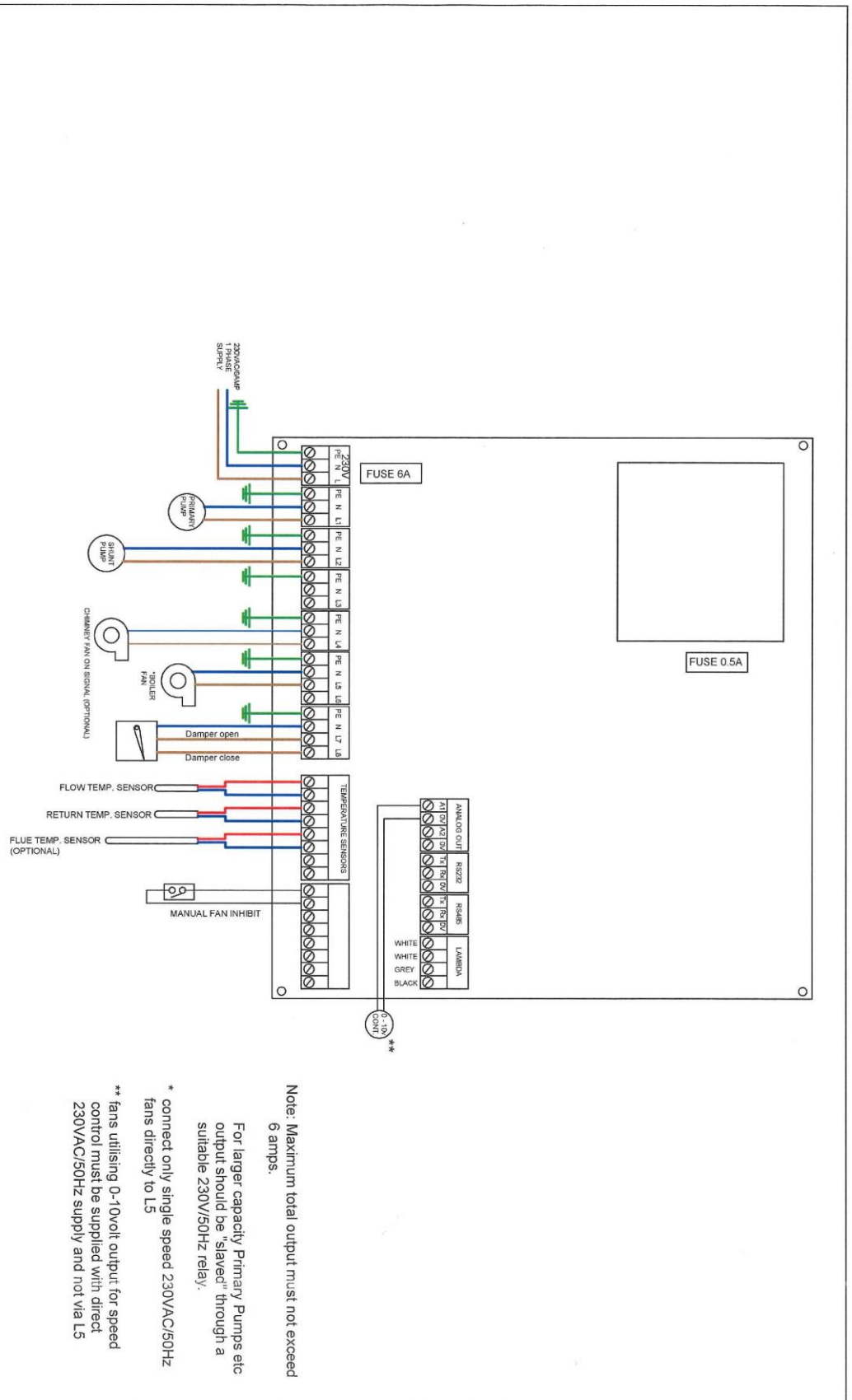

FARM2000
 M&K PRODUCTS (BROMSGROVE) LTD
 Dodford, Bromsgrove, Wores, B61 9BT
 Tel: 01527 821621 Fax: 01527 821965

The original of this drawing is the exclusive property of M&K Products Ltd. and the acceptance of this print constitutes an agreement that it will be treated as a confidential document to be used for the purpose other than aid in the assembly or operation of M&K Products Ltd. These drawings are not to be communicated, disclosed, copied or published except as expressly authorised in writing by M&K Products Ltd.

No.	DATE	ALTERATION

TITLE	TS2 - ELECTRICAL CONNECTION DIAGRAM
DRAWN	TLW
DATE	11/16
MATL.	
SCALE	n.t.s

USED ON	HT36, HT46R, HT50R, HT60R, HT70R, HT80R, BB144/3R, BB146/3R & BB154/3R
DRG. No.	TS2

Note: Maximum total output must not exceed 6 amps.
 For larger capacity Primary Pumps etc output should be "slaved" through a suitable 230V/50Hz relay.
 * connect only single speed 230VAC/50Hz fans directly to L5
 ** fans utilising 0-10volt output for speed control must be supplied with direct 230VAC/50Hz supply and not via L5

